

Making
Even Better
Plastic Welds

by

Donald W. Thomas

Revised by
J.Pierre Pottier
Laramy Products LLC
Lyndonville, Vermont

©1993, Laramy Products LLC
All Rights Reserved

Printed in U.S.A.

CONTENTS

CHAPTER 1	
Introduction to Modern Plastics	1
CHAPTER 2	
Plastic Welding Equipment	7
CHAPTER 3	
Welding of Thermoplastics	12
CHAPTER 4	
Tacking	15
CHAPTER 5	
Hand Welding	17
CHAPTER 6	
Speed Welding	22
CHAPTER 7	
Welding Flexible Plastics and Tank Linings	27
CHAPTER 8	
Special Instructions	35
CHAPTER 9	
Inspecting, Testing and Evaluating Welds	41
CHAPTER 10	
Useful Information	48
CHAPTER 11	
Training Exercises	53

Chapter 1

Introduction to Modern Plastics

Plastics are divided into two basic categories: thermosetting and thermoplastic, much in the same way as metals are divided into ferrous and non-ferrous. Thermosetting plastics harden, under heat or through a chemical reaction set off by a catalyst, into permanent shapes which cannot be changed by reapplying neither heat nor catalysts. Thermosetting plastics, the best known of which are the epoxies and the polyesters (commonly known as fiberglass), are not weldable and therefore will not be looked at any further in this book.

Thermoplastics, however, soften when heated and harden again when cooled without any chemical reaction taking place as long as the melting temperature was not reached. Thermoplastic shapes, therefore, can be molded, formed and welded simply by applying heat and pressure. They may be heated until flexible and cooled again until rigid many times without altering their properties or chemical make-up.

The History and Development of Thermoplastics

The first thermoplastic, celluloid, was actually developed over 120 years ago. However, thermoplastics remained of little importance until the early 1930's when serious research was started in Germany in an effort to find a suitable substitute for their dwindling supply of strategic metals and alloys. Experiments in both the United States and Germany revealed that thermoplastics, when heated, could be pressed together and a permanent bond obtained. In 1938, the principle was incorporated into the "hot gas" welding technique in which the thermoplastic rod and sheet were heated simultaneously by a stream of hot air while the rod was pressed into the sheet causing a bond between the two shapes. Initially, little was made of this process in this country, but World War II forced the Germans into further development and use of welded thermoplastics in their factories as a cor-



Welded Thermoplastic Hoods, Ductwork and Tank Liners In Large Plating Operation

rosion resistant structural material. It was not until after the war that thermoplastics and the “hot gas” welding methods came into use in the United States. Since that time, the plastics industry has experienced a tremendous growth and plastics in many cases have replaced metals for true industrial applications and even more in common items such as appliances, automobiles, housewares and toys.

Thermoplastics in Modern Industry

Thermoplastics are available as either structural materials or as lining materials. Lining materials will be covered in Chapter 7. Common structural applications of thermoplastics include solid forms and fabrications such as plastic pipe and fittings, valves, tubing and rigid sheet and rod. These are relatively new materials of industrial construction which have now earned their place alongside the more conventional materials: steel, wood, concrete, etc.

The primary advantage of structural thermoplastics, such as polyvinyl chloride (PVC), polyethylene (PE) and polypropylene (PRO) over other materials is their resistance to a wide variety of highly corrosive chemicals. This advantage virtually eliminates normal maintenance requirements such as painting and replacement. Thus, even though initial material cost may be slightly higher, in the long run plastics are actually less expensive than many other materials. In addition, plastics are many times lighter than steel, thus easier to handle and cheaper to transport; have excellent electrical and thermal insulating properties; some are nontoxic, thus suitable for food and water processing; have less resistance to internal flow in the case of piping and have excellent resistance against mechanical abuse. The physical properties of nearly all thermoplastics permit the use of conventional tools and procedures for machining and cutting. Thermoplastics can be sawed, sheared, sanded, turned, threaded, drilled, milled, punched, polished and routed. Procedures for joining thermoplastics closely resemble the methods used in metal fabrication, such as bolting, riveting, threading and welding. Some thermoplastics can also be permanently joined by the use of special cements which are not a glue but rather a suspension in a solvent of the same resin as the parts to be joined, leaving behind nothing but the plastic itself after the solvent has evaporated.

Engineers have found many uses for structural thermoplastics in the chemical industry, the oil industry, the nuclear and electronics fields, sewage and waste disposal, electric power generation and distribution, and hundreds of manufacturing operations. A specialized but fast growing field is in body shops for the repair of the new thermoplastic car body parts. Wherever there is a requirement for maximum corrosion resistance or

non-contamination, there is a use for one of the ever widening variety of thermoplastics materials. To meet this demand and further expand applications, the plastic industry is continually developing new plastics which withstand higher temperatures and have better resistance to corrosion and chemical attack.

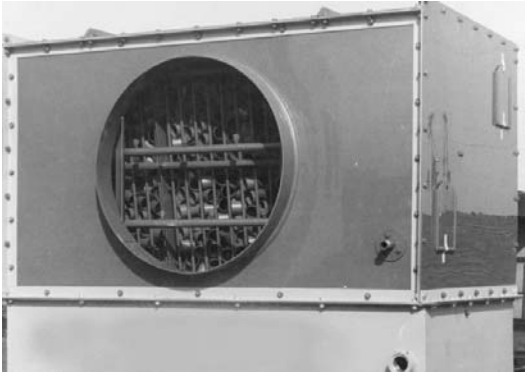

(Courtesy of S&C Mfg. Co.)

PVC Air and Fume Washer

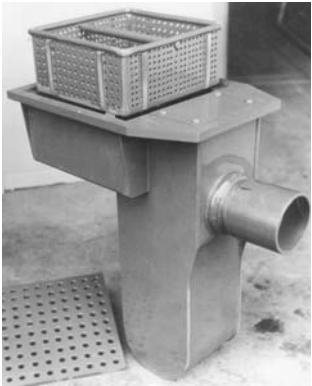

(Courtesy of S&C Mfg. Co.)

PVC Sewer Trap



(Courtesy of Kaykor Industries, Inc.)

Hoods, Ducts and Stacks

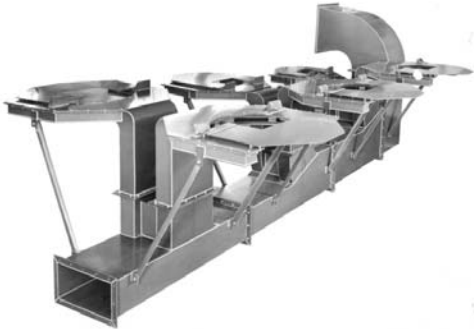

(Courtesy of Colonial Plastics Mfg. Co.)

Fume Exhaust System



(Courtesy of Colonial Plastics Mfg. Co.)

Pipe System

Industrial Applications of Welded Thermoplastics

One of the chief factors in the growth of thermoplastics as structural materials has been the hot gas welding technique. This welding requires only a small investment in equipment and provides versatility, ease, economy and speed in fabrication. The welding process itself may be learned quickly

since it is similar to certain metal welding techniques: primarily brazing and gas welding. Unlike metal welding, however, plastic welding requires little in the way of protective clothing and equipment as the welding temperatures are relatively low and there are no flames or arcs to impede your vision.

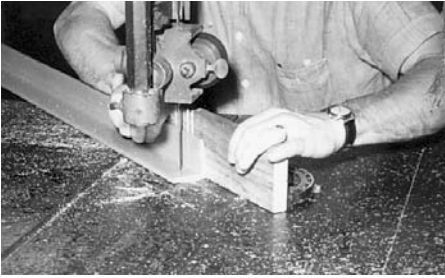

Sawing PVC Angle



Dressing Weld with Rotary Sander

Welding allows rapid and economical fabrication of plastics since welded products may be handled soon after welding and put into service without having to wait for cements to dry and set. The extreme inertness of some thermoplastics such as high density polyethylene, polypropylene, kynar and the teflons, prevents the use of cements for joining and increases the importance of welding as a joining method.

The Future of Thermoplastics

As new thermoplastics have been developed, welding techniques and equipment have been improved to increase speed and make fabrication easier. Welding torches have been streamlined to reduce weight and provide maximum welding efficiency. New designs and construction features simplify and reduce maintenance. The complete line of specialized high-speed welding tips manufactured by Laramy Products allows you to do any job. Those include a speed tip for 1/8" and 5/32" round rod and speed tips for 3/16" and 1/4" round rod as well as tips for 1/8", 3/16" and 1/4" triangular welding rod. Also available are a speed tip for 1/2" x 1/8" welding strip and a complete kit for the specialized welding of flexible tank linings.

During the past thirty years plastic welding in the U.S.A. has grown from an interesting phenomenon practiced by a few specialized people to a recognized and profitable skill practiced by many. It is now an integral part of the booming plastics industry. Trade schools as well as plumbers, steam fitters and sheet metal workers unions training programs have introduced plastic welding courses in their curriculum. The industrial heating and ventilating industry has adopted plastic welding for the fabrication of corrosion

resistant ducts, exhaust hoods, stacks, fans and fume scrubbers used in chemical, plating and manufacturing operations. Welding torches have become standard tools for maintenance departments in plants where plastics are used. Well drilling, piping and building contractors now require equipment for installing plastic pipe. The list is increasing daily and with it the need for plastic welding equipment making it a small but significant part of the overall plastics industry.

Principles of Plastic Welding

The welding of plastics is not unlike the welding of metals. Both methods use a heat source and welding rods and give similar type of finished welds such as butt welds, fillet welds, lap joints, etc. Joints are beveled or otherwise prepared in much the same manner as for metal welding and the joints are similarly evaluated for strength. Due to differences in the physical characteristics of each material, however, there are notable differences between welding thermoplastics and welding metals.

When welding metal, the rod and the parent material are made molten and puddled into a joint that hardens into a weld as it cools. Unlike metals that have a sharply defined melting point at which they become molten, thermoplastics have a varying, but fairly wide, range between the temperature at which they soften and the temperature at which they char and burn in the case of some such as PVC, or the temperature at which they melt in the case of the polyolefins and others. Unlike metals, thermoplastics are poor conductors of heat and therefore difficult to heat uniformly. Because of this, the surface of a plastic welding rod or of the parent material will char or burn before the material below the surface becomes fully softened. The decomposition time at welding temperature is shorter than the time required to completely soften many thermoplastics for fusion welding. The person welding plastics, therefore, must work within a much smaller and more accurate temperature range than the person welding metals.

Because plastic welding rod does not become completely molten and appears much the same before and after welding, to one accustomed to metal welding a plastic weld may appear incomplete. The explanation is simple: since only the outer surface of the rod has become molten and the inner core has remained hard, the welder is able to exert pressure on the rod forcing it into the joint to create a permanent bond. When heat is taken away, the rod reverts to its original form. Thus, even though a strong permanent bond has been obtained between the welding rod and the base material, the appearance of the welding rod is much the same as before the weld was made, except for molten flow patterns on either side of the weld bead.

Technically speaking, all thermoplastics can be welded. Their ability to be welded is governed only by the extent of their melting range; those with the widest melting range are easiest to weld. Today's most widely used industrial thermoplastics are PVC, high density polyethylene and polypropylene.

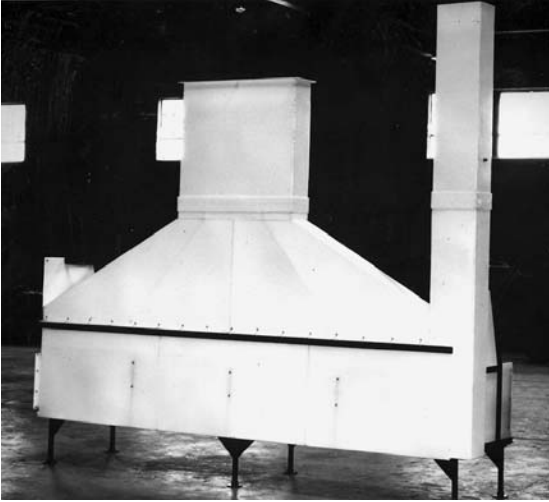

Acid Dispensing Sink and Hood with Forced Air Push-Pull Exhaust – Linear Polyethylene Material

(Courtesy of New England Lead Burning Co., Inc.)



Complete PVC Exhaust System for Metal Finishing Plant

(Courtesy of New England Lead Burning Co., Inc.)

**4 ESSENTIALS
for
Making Even Better Plastic Welds**

- 1. Correct TEMPERATURE
- 2. Correct PRESSURE
- 3. Correct ANGLE
- 4. Correct SPEED

Chapter 2

Plastic Welding Equipment and Accessories

Modern plastic welding torches are all electrically heated but can be divided into two broad categories. The first is the group of torches intended for in-shop use and they are meant to be hooked-up to a source of compressed air or a container of inert gas, usually and preferably, nitrogen. (NOTE: Do not EVER hook up a plastic welding torch to a source of flammable gas or to oxygen.) These shop torches are available with any number of different combinations of controls and accessories giving a wide price range.



The second category is that of the plastic welding torches designed for field use where compressed air is not readily available. These are of two types: units consisting of a standard shop torch but with a portable electric air compressor built into the carrying case and the other being a true self-contained unit where a small motor built into the handle runs a fan and passes a stream of ambient air over the element. These units are light in weight and fairly economical but, due to their design, are bulky and clumsy to use.



All torches heat the air by means of electric heating elements located in the torch barrel and therefore all units require electricity. The temperature range of the torch varies according to the wattage of the element in the unit at the time but, given our range of elements from 250 to 750 watts, the total heat range is from 350 to 1100 degrees Fahrenheit.

Accessories for Plastic Welding Torches

Round tip: This is the most basic tip in plastic welding and is usually provided with the torch when you buy it. It is used for the hand welding of plastics which is mostly done for small or confined work or when the weld has an intricate configuration.

Tacking tip: Used for tacking two thermoplastic parts together. The primary advantage of tacking prior to welding is that one obtains a neater weld and a stronger weld. Tacking also eliminates the need for jigs, fixtures or clamps.



Combination Round and Tacking Tip

Speed welding tips: As mentioned in chapter one, speed tips come with feed tubes of various sizes and shapes to accommodate different shapes and sizes of welding rods. These tips have two tubes feeding hot air from the barrel. The lower one preheats the sheet while the upper one, to which the feed tube for the rod is welded, preheats the rod and heats at the weld point. These tips allow welding speeds about four times that of hand welding. They are ideal for long, straight and flat welds and are also suitable for pipe welding on pipes of at least 4" diameter.



Speed Welding Tip

Gas and Power Control Unit: This unit, commonly known as a nitrogen saver, reduces the use of costly inert gas by automatically switching from nitrogen to compressed air when the torch is not in actual use and is resting in its bracket. It also has a pressure-sensitive switch which shuts off all

power to the unit if either the nitrogen or compressed air pressure drops below a certain point. This prevents burning out elements.



Nitrogen Saver

Related Equipment and Accessories

There are a number of contact welding tools made, also known as fusion welding tools. The principle is that the two pieces to be joined are pressed against a heated tool until the edges meant to meet are starting to melt. The tool is withdrawn and the edges pressed together. The tool is usually teflon coated to prevent sticking. Laramy Products has a pipe welder which falls into this category. The heated tool is not coated but accepts a variety of coated dies in pairs (one male and one female) of various metric or IPS sizes. The pipe end is inserted in the female die while the fitting is slipped over the male die. When the inner surface of the fitting and the outer surface of the pipe are starting to melt, they are removed from the tool and the pipe is quickly pressed into the fitting. This is mostly used with polyethylene, polypropylene and kynar pipes.



Fusion Pipe Welder

There are also tools designed to heat plastic sheets so they can be bent at different angles. Those are of different types, some of which are highly automated and equally highly expensive. Laramy Products offers two very simple types which are suitable to and affordable by the small fabricating shop. One consists of two bars controlled by one control so that both are always at the same temperature. The control is set so as to obtain the



Laramy Plastics Bending Bar Set



Laramy Plastics "Sword"

proper softening temperature for the material to be bent. The sheet is inserted between the bars for a period determined by the thickness of the sheet and then removed and bent at a different station. It should be held at the desired degree of bend until the sheet has cooled enough to hold the bend. The other system has only one bar controlled by a similar control. On that bar is attached an extruded aluminum "sword" with a 90 degree edge. The sword is placed on the desired bend line and allowed to melt its way through two thirds to three quarters of the way. At this time, the sword is removed, the sheet bent and the two molten edges fuse. This method makes a near perfect right angle bend without radius, but is only suitable for polyethylene, polypropylene and kynar. The bar method works on ALL thermoplastics but makes a radius bend with the radius being three times the thickness of the sheet.

Spark testers are useful to the fabricators to test for leaks. They are basically a portable transformer which takes standard 110 volts current and transforms it to high voltage, low amperage current coming out through a probe. If a grounded conductive material is placed behind the weld and the probe passed on the outside, you will only see a blue haze if the weld is whole. If, however, you suddenly see a bright spark going through the material, there is a "holiday" in your weld at the point where the spark was generated.

Although not really an accessory, this is probably the place to mention welding rod. It must always be of the same material as what you wish to weld. Welding rod of most common plastics is readily available practically any-

where in the U.S. Rods for some of the less common plastics can be hard to come by. As mentioned in the first chapter, rods come in a variety of shapes and sizes.

Basic Rules for Welding Plastics

1.If using compressed air, make sure your air supply is clean. Moisture in the air will short-circuit and burn out the heating element in your torch; and oil in your air line will contaminate the weld and eventually ruin your element. If using nitrogen, be sure you use so-called “dry” nitrogen.

2.Always let air or nitrogen run through your torch BEFORE turning electricity on. Also let air run for five minutes after turning the power off. This cools the element and prolongs its life.

3.Make sure you use only three wire grounded systems.

4.The temperature of the welding gas is determined by the size element you use and, within that element’s range, by the flow of air over the element. The LOWER the pressure, the HIGHER temperature. Conversely, the higher the pressure, the lower the temperature. The normal operating range of an element is between 2 1/2 and 3 1/2 pounds pressure. If you must go higher or lower to obtain the temperature you need, you should change elements. To find out the temperature you are operating at, check it with an accurate thermometer held about 1/4" from the end of the welding tip.

5.NEVER grab the torch by the barrel or the tip even if you could swear it is not turned on. That way, you will avoid the possibility of suffering painful injuries.

6.PLEASE read the instructions that come with the particular brand or model of torch you have BEFORE using it for the first time!

4 ESSENTIALS for Making Even Better Plastic Welds

- | | |
|------------------------|------------------|
| 1. Correct TEMPERATURE | 3. Correct ANGLE |
| 2. Correct PRESSURE | 4. Correct SPEED |

Chapter 3

Welding Plastics

Although general procedures for welding plastics are similar to welding metals, there is a definite knack which must be learned before successful plastic welds can be made. Since the quality of the finished weld is directly proportionate the skill of the welder, the beginner should first become familiar with thermoplastics and their properties. Only after this familiarity is gained should the beginner attempt to acquaint himself with the operation and maintenance of today's equipment and the modern techniques of plastic welding.

Types of Welds

Although welding procedures differ, the same basic types of welds are used by both metal welders and plastic welders. Some of the more commonly used plastic welds are shown below:

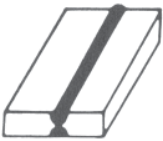

**Double-V
Butt Weld**

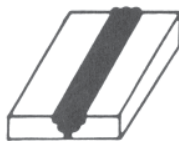

**Multiple Bead
Single-V Butt Weld**



**Multiple Bead
Double-V Butt Weld**



Corner Weld



Edge Welds



Fillet Weld



Lap Fillet Weld

Types of Welds

Preparation of Materials

In common with all successful endeavors, sound plastic welds start with proper planning and preparation.

Size and shape of the welding project; type, shape and thickness of the material to be welded; stresses which the completed project will be subjected to; position of materials for welding; unusual circumstances surrounding the welding; and many other factors influence the selection of the

type of weld to be used. This is often determined by the project engineer, job supervisor, or by the welding operator according to his ability and experience.

Butt Welds, Edge Welds, and Corner Welds: To prepare material for the welding of butt joints (butt welds), edge welds and certain types of corner welds, bevel the edges of both pieces, using a saw, jointer, sander or block plane. Do not bevel to a feather edge; leave about a 1/32" flat. The two pieces when placed together should now have a "V" groove with an angle of 60°. Most shops will operate at 50°-55° to cut the number of passes.

In order to create a good bond in the finished weld, the two surfaces to be joined must be free of all dirt, dust, oil, moisture and loose particles of material. Wipe the edges using a clean cloth. Do not use solvents to clean beveled edges since they tend to soften the edges causing a poor finished weld.

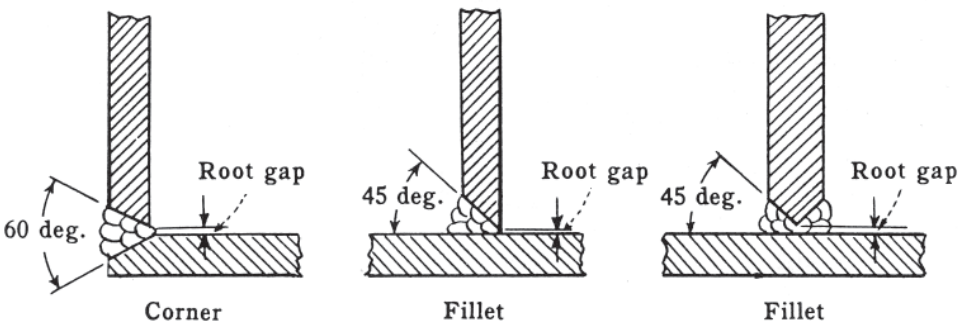
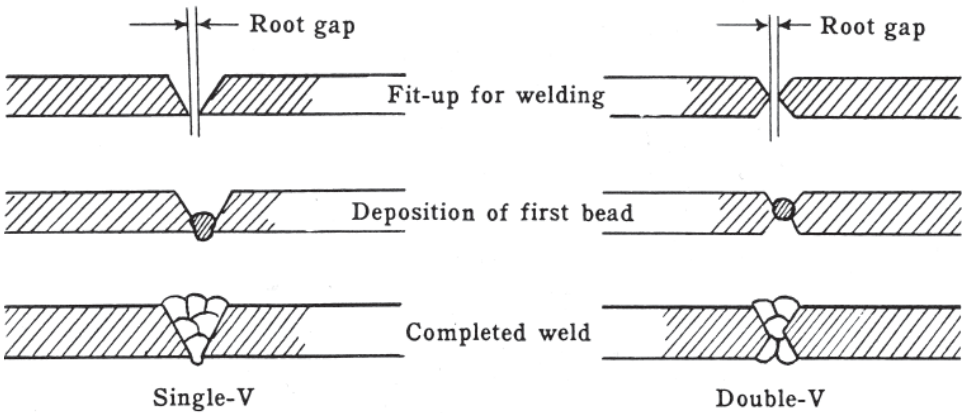

Beveling and Preparation

Place the pieces to be welded together. If pieces are to be tacked together with tacking rod, leave a root gap of 1/64" - 1/32" between the pieces. Do not leave a root gap when using the tacking tip for the tacking operation.

Lap Welds: Lap welding requires little preliminary preparation since the pieces to be joined are placed one atop the other. As with the welds described above, surfaces must be clean and free of all dirt, dust, oil, moisture and loose particles of material. To hold pieces firmly together for welding, "C" clamps may be used or a tack weld applied.

Fillet Welds: Fillet welds and lap fillet welds require little preliminary preparation. Pieces to be joined must be clean and free of all dirt. Pieces to be joined must be held securely in the desired position, using clamps, blocks, tack welds or hand. When making fillet welds with one or both edges beveled, be sure to leave a root gap of 1/64" - 1/32" if tacking tip is not used.

Rosette Welds: Rosette welds are similar to lap welds. Little preliminary preparation is required other than cleaning and the drilling of holes of the desired size and position. To drill holes, use any hand or electric drill.

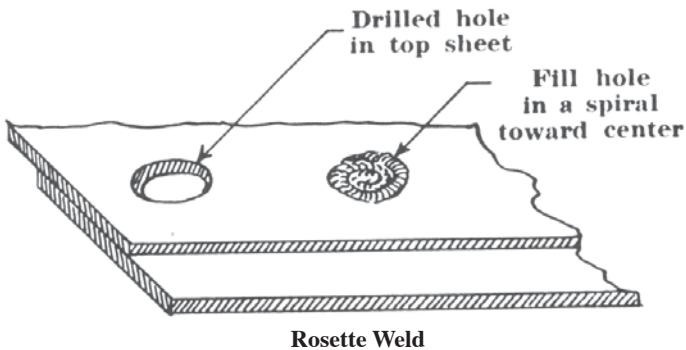

Back Welding Cemented Joints

Before back welding cemented joints, allow cement to cure for at least six hours. Be sure all cement residue is removed with a knife, sandpaper, emery cloth, wire brush or router before welding.

4 ESSENTIALS for Making Even Better Plastic Welds

1. Correct TEMPERATURE
2. Correct PRESSURE
3. Correct ANGLE
4. Correct SPEED

Chapter 4

Tacking

Just as in metal welding, tacking is a method of superficially joining together pieces to be welded in order to hold them in position for final welding. With plastic welding, this may be accomplished either by the use of a small diameter rod or with a tacking tip on the operator's torch.

Tack welding with rod is similar to hand welding except that the use of a smaller welding or tacking rod allows greater welding speed. (See "Hand Welding".)

The tacking tip is a pointed shoe which is attached to the welding torch and heated with hot gas from the torch. By applying pressure on this pointed tip, material softened by the heat is fused together. Advantages of the tacking tip are primarily its great speed and neatness. Use of the tacking tip also eliminates a potential source of weakness in completed welds caused by rod tacks left in place. Most important, jigs and clamps are not necessary, and one hand is free to hold work together.

The pointed tacking tip is held by the operator at an angle of approximately 80° and placed directly on the joint to be tacked. Then, much as if it were a pencil, the operator slowly draws a line along the joint.

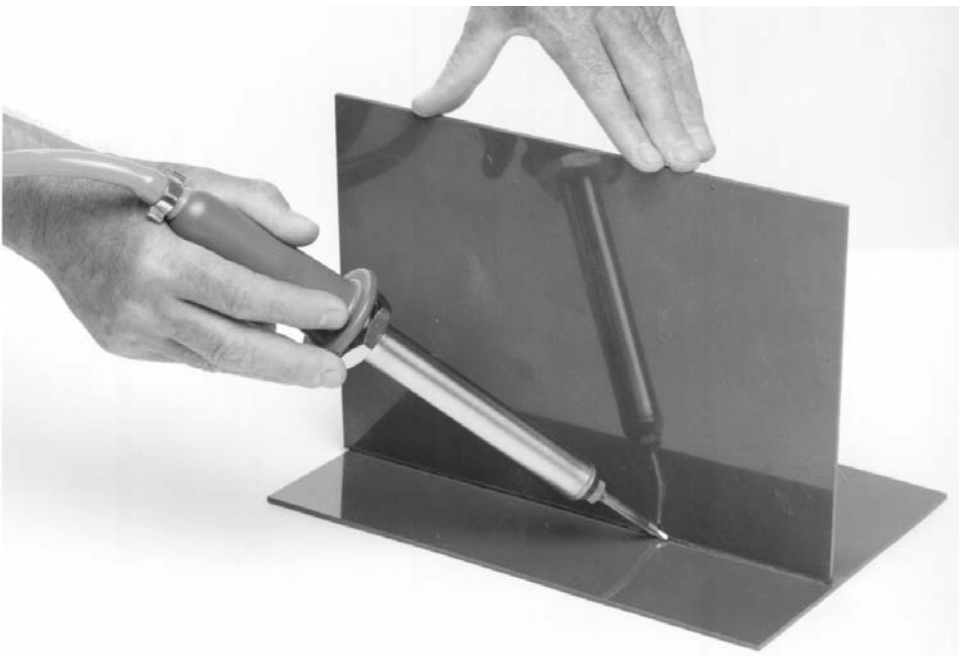

Tacking Sheets Together

When pieces to be welded are large or unwieldy, short tacks are often made at strategic points, such as corners, at regular intervals. These short tacks help to hold in place the pieces to be tacked. With the partially tacked pieces in the proper position, the tacking tip may be drawn around the entire joint creating a continuous seal. The resultant tack will hold together large pieces of material sufficiently well so they can be handled and moved without coming apart. If the welder wishes to reposition the pieces, the tack weld may be broken and retacked.

The welder is now ready to make a completed weld using one of the methods shown in the following chapters. Since the pieces to be welded are held in place by the tack weld, no jigs or clamps are necessary and the operator has both hands free.

Note: Tacking produces only a superficial weld which has little strength. It should not be considered a completed weld.

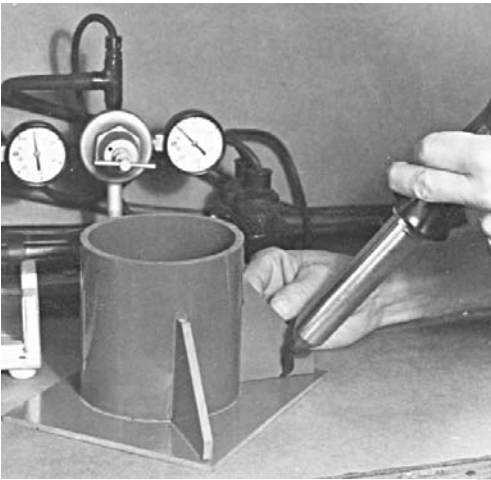

Tacking Braces to Upright Pipe

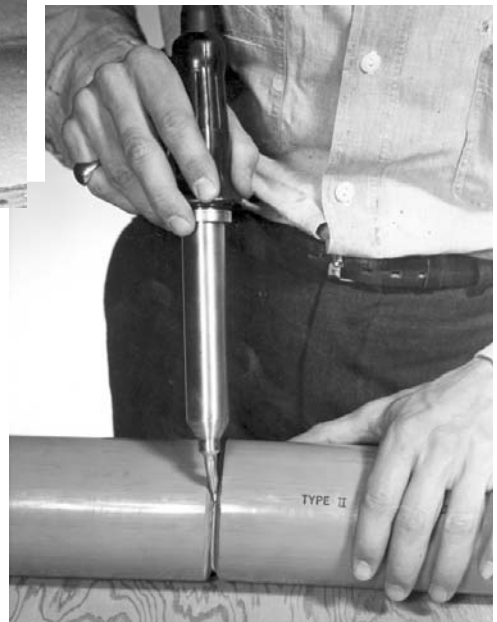

Tacking Butted Pipe Sections

(Courtesy of A.M. Byers Co.)

Chapter 5

Hand Welding

In the welding of plastics, materials are fused together by a proper combination of heat and pressure. With the conventional hand welding method, this combination is achieved by applying pressure on the welding rod with one hand while, at the same time, applying heat to the rod and base material with hot gas from the welding torch. Successful welds require that both pressure and heat be kept constant and in proper balance. Too much pressure on the rod tends to stretch the bead and produce unsatisfactory results. Too much heat will char, melt or distort the materials.

Preparation for Welding

With the torch ready for welding (tip inserted, welding gas and current turned on) check temperature by holding the bulb of a thermometer 1 1/4" from the end of the tip. When welding PVC the correct temperature may be easily determined by holding the tip 1/4" from the material and counting off four seconds in the following manner: (slowly) one and two and three and four. At the count of four, the material should show a faint yellowish tinge. Adjust temperature accordingly.

Select the proper filler rod. (See Chapter 10.) With a sharp knife or cutting pliers, cut the filler rod to the desired length (slightly longer than the length of the intended weld) at an angle of 60°. This provides a thin wedge which is easily heated and facilitates starting the weld.

Starting the Weld

Holding the torch with the tip 1/4" - 3/4" from the material to be welded, preheat starting area on the base material and rod until it appears shiny and becomes tacky. Hold the rod at an angle of 90° (for polyethylene and fluorocarbons the angle should be 45°) to the base material and move it up and down slightly so that it barely touches the base material. When heated sufficiently, the rod will stick to the base material. To maintain the correct balance of heat, the torch should now be moved in a vertical fanning or weaving motion so as to heat both the rod and base material equally. At the same time, the rod should be pressed into the material with a slight downward pressure (approximately 3 lbs.). When a molten wave becomes evident where the rod meets the base material, the rod should bend and begin to move forward. Overheated rod becomes rubbery and makes the application of even pressure virtually impossible. Overheated base material will char or melt causing an unsatisfactory bond.

When welding plastics, a good start is essential. It is at the starting point that welds most frequently fail. For this reason, starting points on multiple bead welds should be staggered whenever possible.

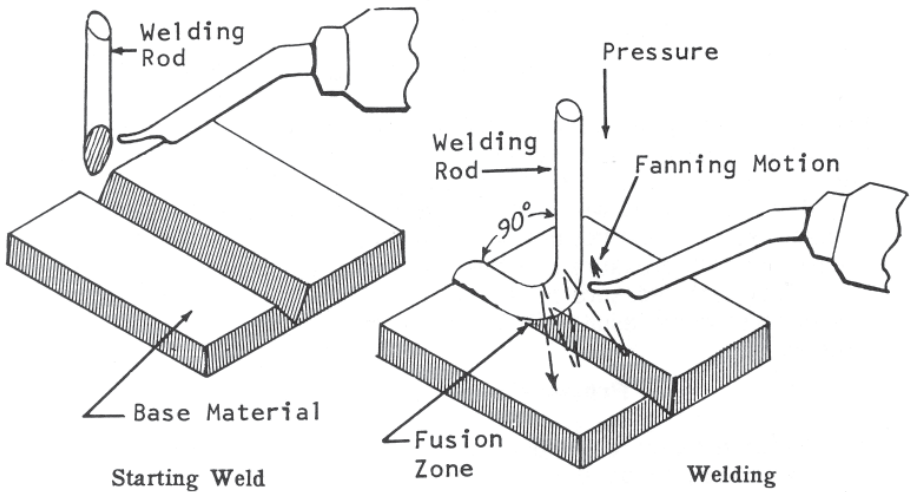

Continuing the Weld

Once the weld has been started, the torch should continue to fan from the rod to the base material with approximately two full oscillations per second. Because the welding rod has less bulk than the base material, it heats more rapidly. To compensate for this difference in bulk, the arc of the fanning motion should be concentrated on the base material approximately 60% of the time when using 1/8" rod; and approximately 40% of the time when using 5/32" rod. The fanning motion should heat 1/2" of the welding rod and 3/8" forward of the rod on the base material. Average welding speed should be 4" to 6" per minute.

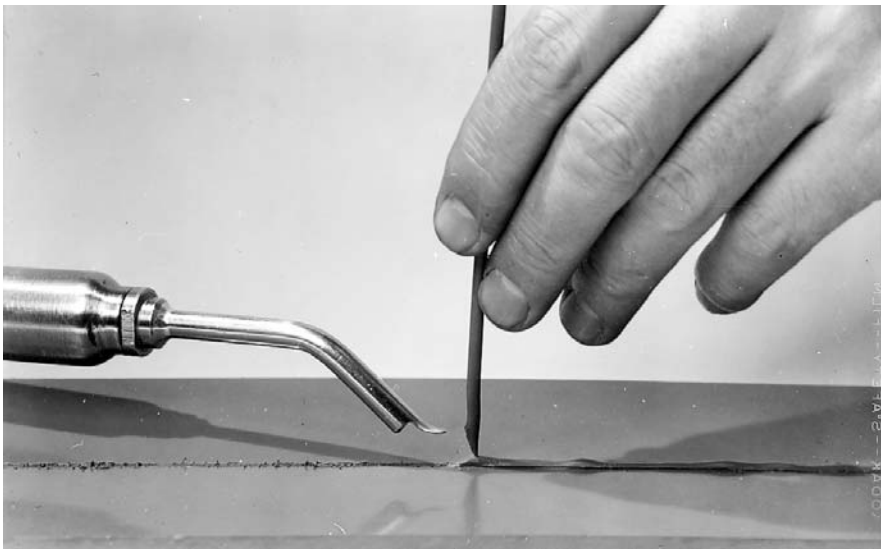

Continuing the Weld

Correct Angle of Welding Rod

When welding PVC, the rod should be held at an angle of 90° to the base material. Although greater welding speed can be obtained by leaning the rod past the perpendicular (away from the direction of welding), the resultant stretching of the rod produces checks and cracks in the finished weld upon cooling. In order to exert sufficient pressure on polyethylene rod, it must be fed into the weld bed at an angle of 45° to the direction of the weld with the upper part of the rod looping away from the direction of the weld. For fillet welds, the rod should be held in such a way that it bisects the angle between the two welded surfaces. In most cases, this will be a 45° angle. It is essential to preheat all surfaces being joined. When butt welding PVC pipe, the welding rod should always point towards the center of the pipe to prevent stretched welds.

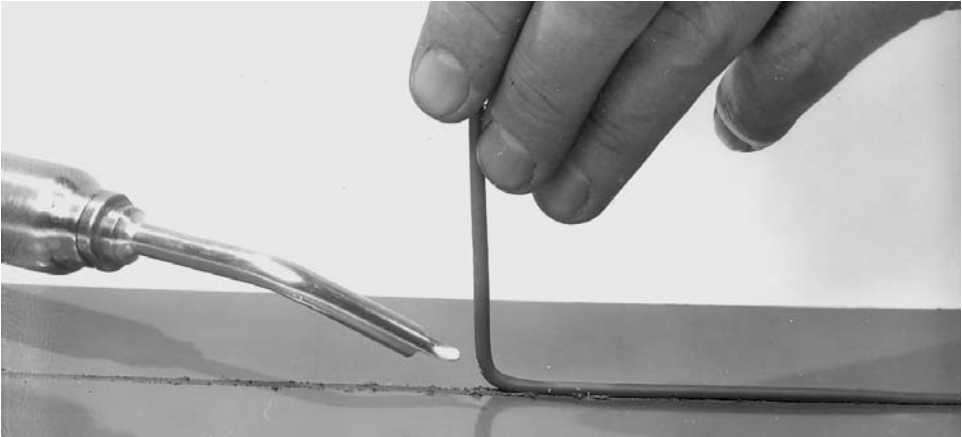

PVC

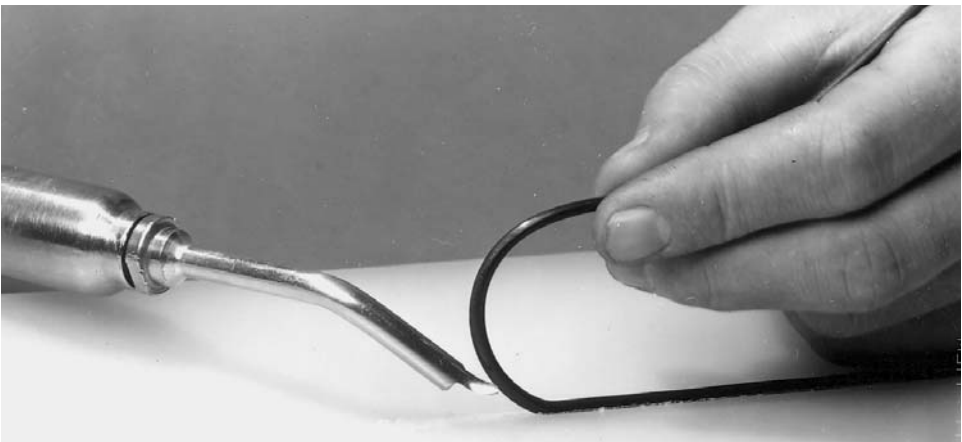

Polyethylene

Correct Angle of Welding Rod

Feeding the Rod

In the process of welding, the rod will, of course, eventually be used up, making it necessary for the welder to renew his grip on the rod. Unless this is performed carefully, the sudden release of pressure may cause the rod to lift away from the weld bed, causing air to become trapped under the weld and resulting in a weak weld ... often in complete weld failure. To eliminate this possibility, place the 4th and 5th fingers on either side of the rod to maintain pressure while repositioning the thumb and forefinger. If this movement is too difficult, place the 3rd or 4th finger in top of the already deposited bead (it should be cool since only the bottom surface is exposed to heat) and hold the rod down while repositioning thumb and forefinger. Then resume normal pressure. When using the latter method, caution should be taken to turn the torch away from the working area to eliminate any danger of burning fingers.

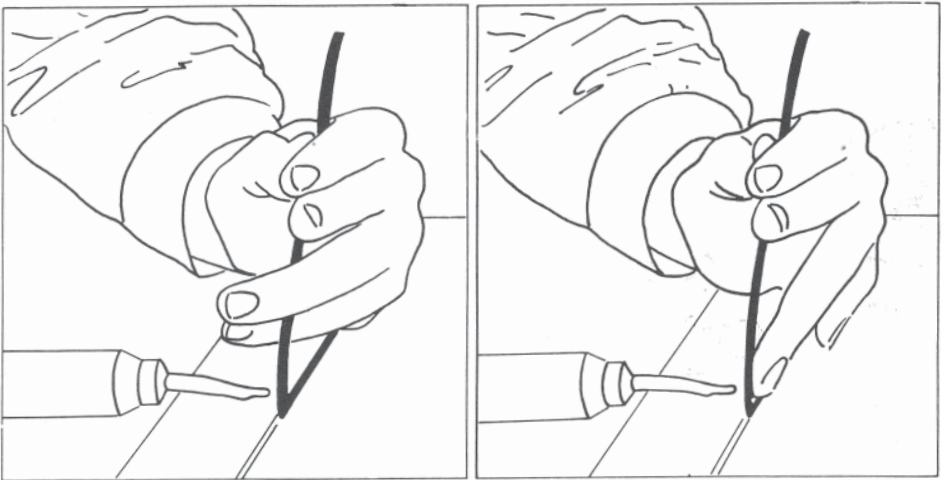

Methods of Re-Positioning Grip on Rod

Finishing the Weld

When a weld is to be terminated, stop all forward motion, and direct a quick application of heat directly at the intersection of the rod and the base material. Remove heat; maintain downward pressure on the rod for several seconds. Allow rod to cool for several seconds to prevent possibility of bead being pulled from its bed. Then, release downward pressure; twist rod with the fingers until it breaks. If a continuation weld is to be made, the deposited bead should be terminated by cutting at an angle of 30° with a sharp knife or cutting pliers after allowing rod to cool for several seconds under pressure. When joining one rod to another in a continuation weld, cut the new rod at a 60° angle. Heat 60° angle surface of new rod and weld on

angle of the old rod so that pieces joined together appear to be almost one piece. Never splice welds by overlapping side by side. When terminating weld, as in the case of pipe welding, weld should always be lapped on top (not beside) of itself for a distance of 3/8" to 1/2".

When welding PVC, a good finished weld will appear comparatively uniform with no brown or black discoloration. If insufficient heat has been applied, the rod will appear in its original form and can easily be pulled away from the base material. Small flow lines or waves on either side of the bead should be evident on a satisfactory weld. In the case of polyethylene, polypropylene and chlorinated polyether, an overheated weld will produce a flat bead with oversized flow lines. Polyethylene and polypropylene do not char or discolor when overheated but become transparent much like hot candle wax.

When welding heavy sections of material, multiple beads are welded in the joint, one on top of the other. Caution must be exercised when running these multiple beads so that the whole mass does not become overheated and produce a bad weld. When back welding a cemented pipe, be sure all cement at the joints is removed. When welding pipe, be sure the 90° angle is maintained at all times between the rod and the base material. To decrease number of welding runs when laying multiple beads, use large size rod: 5/32" or 3/16". As a rule of thumb, a minimum number of beads should always be used. The finished weld should always overlap the beveled edge of the base material.



Butt Welding PVC Pipe

Chapter 6

Speed Welding

High speed welding incorporates the basic methods utilized in hand welding. Its primary difference lies in the use of a specially designed high speed tip which enables the welder to produce more uniform welds and work at a much higher rate of speed. As with hand welding, constant heat and pressure must be maintained.

Principle of Speed Welding

The increased rate of welding in high speed welding is made possible through preheating of both the welding rod and the base material before the point of fusion. The rod is preheated as it passes through a tube in the speed welding tip. The base material is preheated by a stream of hot air passing through a vent in the tip ahead of the fusion point. A pointed shoe on the end of the tip supplies pressure on the rod and eliminates the need for the operator to apply pressure. At the same time it smooths out the rod, giving a more uniform appearance to the finished weld.

Advantages of Speed Welding

In high speed welding, the conventional two hands welding method becomes a faster and more uniform one hand operation. Once started, the rod is fed automatically into the preheating tube as the welder is pulled along the joint. High speed tips are designed to provide the constant balance of heat and pressure necessary for a satisfactory weld. Average welding speeds are about 40" per minute for PVC and 24" to 30" for polypropylene.

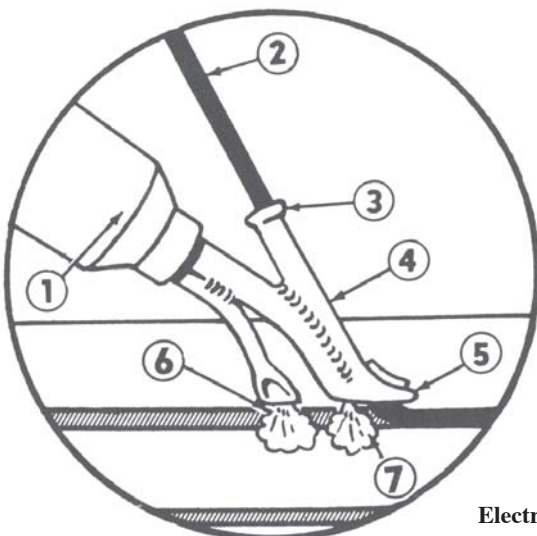

- 1 Electric Torch
- 2 Welding Rod
- 3 Speed Tip
- 4 Rod is Pre-heated in Tube
- 5 Shoe Provides Pressure
- 6 Orifice Pre-Heats Area to be Welded
- 7 Heat

Electric Torch with Speed Welding Tip

Starting the Weld

With the high speed torch held like a dagger and the hose on the outside of the wrist, bring the tip over the starting point about 3" from the material so the hot air will not affect the material. Insert the welding rod into the preheating tube and immediately place the pointed shoe of the tip on the material at the starting point. Hold the welder perpendicular to the material and push the rod through until it stops against the material at the starting point. If necessary, lift the torch slightly to allow the rod to pass under the shoe. Keeping a slight pressure on the rod with the left hand and **only the weight of the torch** on the shoe, pull the torch slowly toward you. The weld is now started.

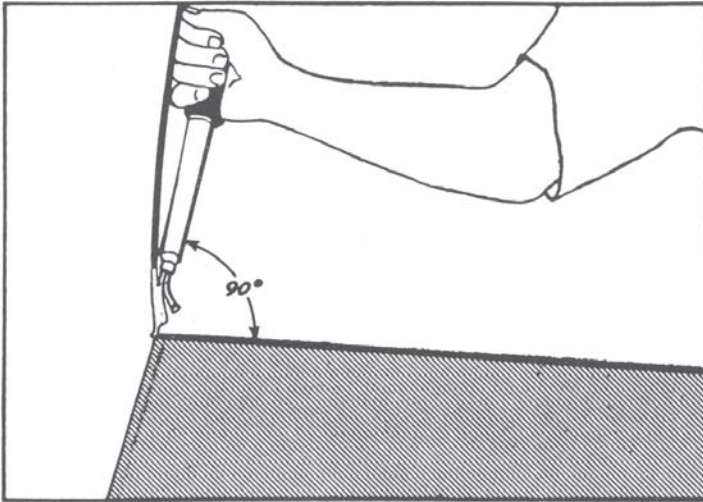

Starting Weld

IMPORTANT: Once the rod is inserted in the preheating tube, the remaining steps in the procedure must follow in rapid sequence to prevent scorching or melting of the rod. **Do not** insert the rod in the tip until you are ready to go.

Continuing the Weld

In the first inch or two of travel, the rod should be helped along by pushing it into the tube with a slight pressure. Once the weld has been properly started, the torch is brought to a 45° angle and the rod will feed automatically without further help. As the torch moves along, visual inspection will indicate the quality of the weld being produced. When welding PVC, brown or charred edges of rod indicate a poor weld caused by welding too slowly. If the rod has been softened too much by overheating it will stretch and break, or flatten out. When welding polyethylene or polypropylene too slowly the rod will flatten out and the transparent flow lines on each side of the bead

will appear oversized. Absence of flow lines indicates insufficient pressure or a welding rate that is too fast.

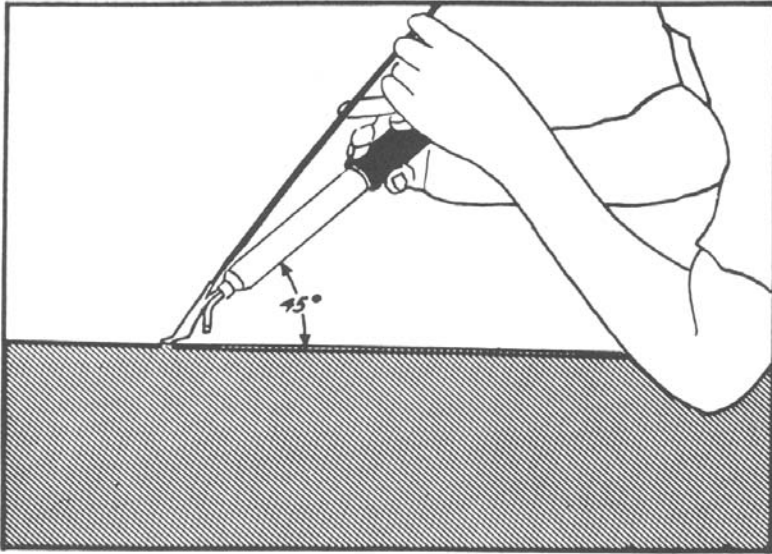

Continuing the Weld

The angle between the torch and the base material determines the welding rate. Since the preheater hole in the speed tip precedes the shoe, the angle of the welder to the material being welded determines how close the hole is to the base material and how much preheating is being done. It is for this reason the torch is held at a 90° angle when starting the weld and at 45° thereafter. When a visual inspection of the weld indicates a welding rate which is too fast, the torch should be brought back to the 90° angle temporarily in order to slow down the welding rate, then gradually moved to the desired angle for proper welding speed. It is important that the welder be held in such a way that the preheater hole and the shoe are always in line with the direction of the weld, so that only the material in front of the shoe is preheated. A heat pattern on the base material will indicate the area being preheated. The rod should always be welding in the center of that pattern.

Finishing the Weld

It is important to remember that, once started, speed welding must be maintained at a fairly constant rate of speed. The torch cannot be held still. To

stop welding before the rod is used up, bring the torch back past the 90° angle and cut off the rod with the end of the shoe. Stopping the weld before the rod is used up may also be accomplished by pulling the speed tip off the remaining rod. When cutting the rod with the shoe the remaining rod must be removed promptly from the preheater tube. Rod not removed promptly from the preheater tube will char or melt, clogging the tube and making it necessary for the tube to be cleaned out. This may be accomplished by inserting a new rod in the tube.

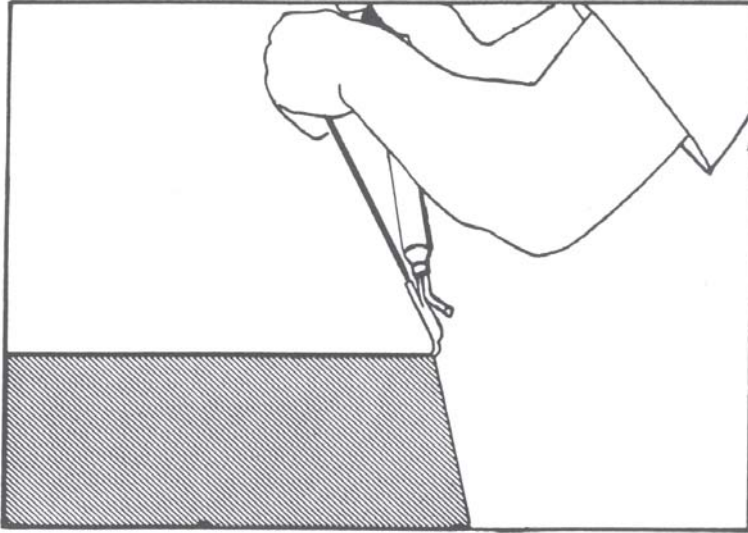

Finishing the Weld

A good speed weld in a “V” joint will have a slightly higher crown than the normal hand weld and more uniformity. It should appear smooth and shiny, with a slight bead on each side. For best results and faster welding speeds, the shoe on the speed tip should be cleaned occasionally with a wire brush to remove any residue which might cling to it and create drag on the rod.

Work Limitations

The modern high speed plastic welding torch is designed primarily to meet the needs of production type welding. Since increased speeds must be maintained in order to procure good welds, the high speed welding torch is not suited for small intricate work. At first the position in which the welder is held may seem clumsy and difficult. However, practice and experience will soon enable the welder to successfully make all welds made with a hand welder, such as butt welds, “V” welds, corner welds and lap joint welds. Speed welds can be made on circular as well as flat work, and on all outside welding of hoods and ducts. In addition, inside welds on tanks can be speed welded unless the working space is too small to manipulate the torch.



Speed Welding Polyethylene Sheet

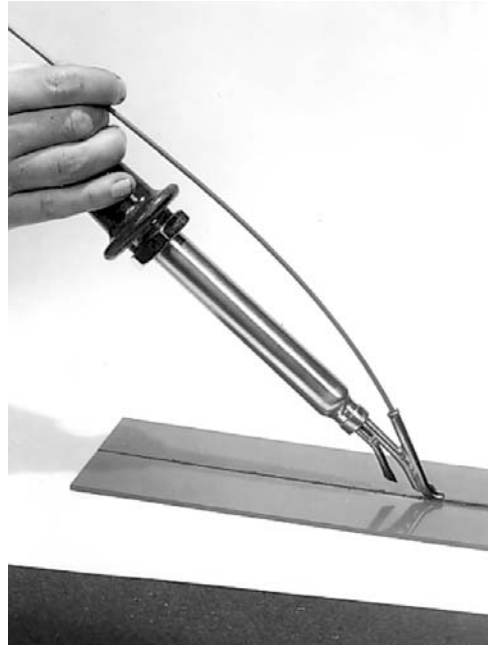

Speed Welding PVC Sheet



Speed Welding Pipe

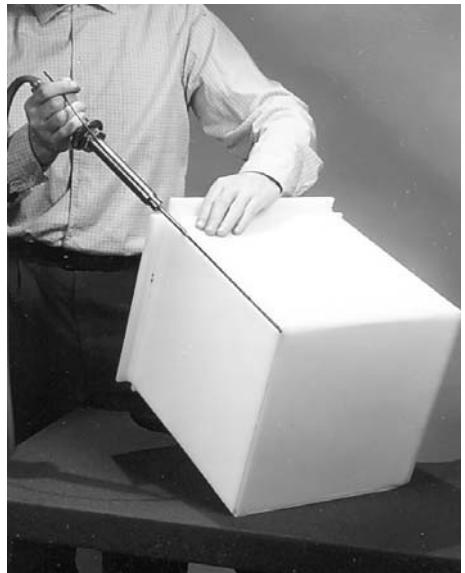

Speed Welding Tank

Chapter 7

Welding Flexible Thermoplastics and Tank Lining Materials

In addition to many structural applications, thermoplastics are used extensively for the lining of non-plastic structures and vessels. Thermoplastics, used as lining materials are gradually replacing the previously common methods of lining such as lead, brick, tar, rubber or glass. The fabrication of thermoplastics for complete structures and vessels is necessarily restricted due to strength requirements and costs. However their use as a noncorrosive lining material has opened many new fields. Using special adhesives, thermoplastic linings can be applied to metal, wood, or concrete. The seams of the linings are welded with strip or round rod, providing a continuous leak-proof surface. The end product provides both maximum protection against corrosion and the necessary rigidity. There are advantages which the materials by themselves could not provide.

More recently a new kind of lining materials has come into use. These are known as geomembranes and can be of woven synthetic, or in some cases of relatively thin flexible polyethylene. The latter is used primarily for the lining of landfills and is always welded to prevent leaks.

Another material now commonly used to line chemical processing equipment is F.E.P. fluorocarbon (teflon) and its newer relative P.F.A.

Types of Lining Materials

Thermoplastics used for welded liners fall into three categories: rigid, flexible, and a combination of both. The rigid-type linings use either a thin "foil" of thermoplastic sheet which is cemented to a vessel and then welded, or a self-supporting thermoplastic container which is welded to fit the vessel to be lined and upon completion dropped inside. This "drop in" liner may be bolted to the vessel if desired. Outlets are welded in after the liner is in place. Rigid strip or round rod is used for welding.

Plasticized PVC sheet 3/32" to 1/4" thick is used for flexible linings. This sheet is cemented to the inside of a vessel and the seams welded with flexible flat or contoured corner strip.

A PVC sheet, which is a combination of rigid and flexible sheets laminated together, is the third type of thermoplastic lining available. The flexible side is cemented to the vessel and the rigid side exposed to the corrosive liquids. All welding is done on the rigid inner side of the sheet with either rigid strip or round rod.

The thin flexible teflon materials belong to the first category. The fact that they are difficult to bond, difficult to weld, and very expensive has restricted their use, but in high temperatures and high corrosion applications, there is no substitute for them.

All three types of linings are used extensively in plating and storage tanks, vats, sewerage systems, pipelines, and ventilating systems. The techniques for welding with rigid round rod have been outlined in the preceding chapters. This chapter will cover the welding equipment and techniques used with flexible PVC and rigid stripping.

Torches: Electrically heated, hot air torches similar to those used for welding structural thermoplastics are suitable for welding flexible vinyl strips and rigid strips. Since these strips have more surface area and bulk than a rod, higher wattage heating elements must be used in the torches to produce more heat and allow a reasonable rate of welding. The new geomembranes and also polypropylene liners should be welded with nitrogen.

Welding Tips and Accessories

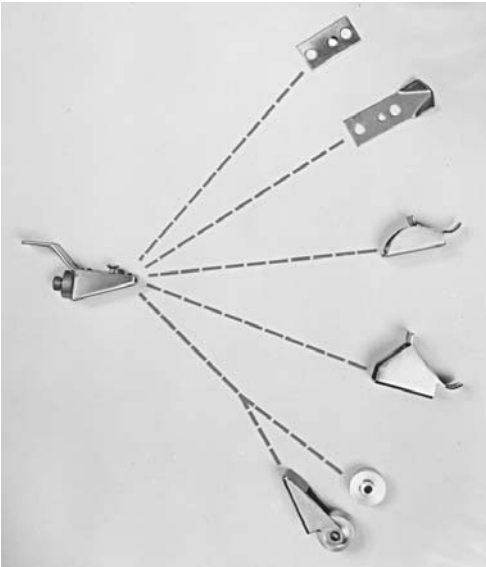

Lining Tip Kit

Flat Tip 5/8"

"V" Tip

Auto Seal Tip 5/8" & 3/4" wide strip

Auto Seal Tip 1" wide strip

Penton Tip (Flat and Corner)

Flat Tip: Used for welding extruded flat welding strip on flat butt joints. Its ability to heat the full width of the strip saves time and produces uniform welds.

"V" Tips: Used for welding extruded corner strip on corner fillet welds and outside corner welds. This tip confines the hot gas flow to the angular welding surfaces.

"Autoseal" Tip: Used for welding both flat and corner flexible strip. This tip imparts pressure to the strip by means of a shoe and preheats both the strip and the base material, thus increasing the rate of welding.

Rigid "Autoseal" Tip: Used for welding both flat and corner flexible strip. This tip imparts pressure to the strip by means of interchangeable con-

toured rollers so that drag on the strip is minimized. The strip is preheated by introducing hot gas into the feeding chamber, softening the rigid strip sufficiently to allow semi-automatic feeding as the torch is moved along the joint.

Types of Welds

Flexible Linings

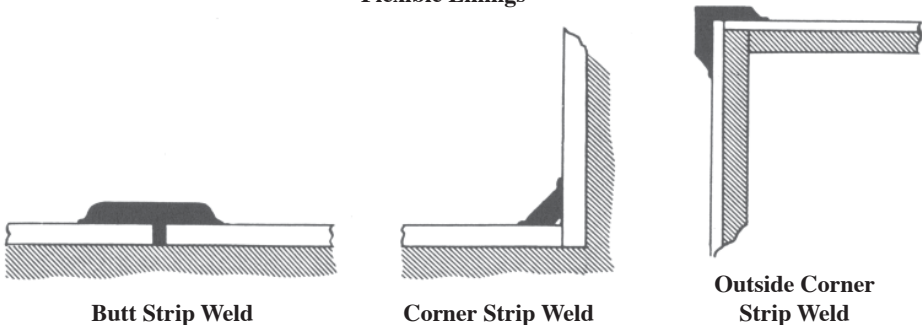

Rigid and Combination Flexible-Rigid Linings

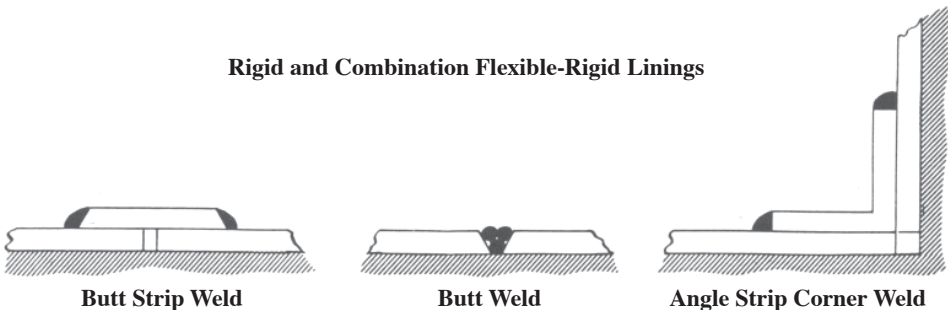

Types of Welds

There are four basic types of strip welds in lining work: butt strip weld, corner strip weld, outside corner strip weld, and lap weld. These welds are made with strips extruded from material similar to the sheet.

Butt Strip Weld: Joins strips together on flat surfaces using a flat strip 5/8" to 1" wide and 3/32" thick with beveled sides. These sheets are not beveled on the butted edges unless a root weld with round plasticized rod is used. Such a root weld lends strength to the joint and insures complete leak tightness. Welding is done with a flat tip and strip feeder or Autoseal tip.

Corner Strip Weld: Joins sheets together where they meet on inside corners. Corner strip is from 5/8" to 1" wide on top and from 1/4" to 1/2" wide on bottom. These strips vary in thickness from 3/8" and up and the sides are shaped on the angle of 45° with top of strip. Each manufacturer favors a certain size and shape strip. Welding is done with a "V" tip and strip feeder or Autoseal tip.

Outside Corner Strip Weld: Joins sheets which come together on outside corners as in lining the outside of a tank. Each leg of the strip is 1/2" wide and 3/32" thick. Welding is done with a "V" tip only.

Lap Weld and Lap Strip Weld: The lap weld joins sheets together on a flat surface without the use of a strip. The meeting surfaces of the joint are heated using a round or flat tip. When these surfaces become tacky they are pressed together with a roller, causing a weld. This type of weld is not recommended for tank work since it leaves an air pocket under the uppermost sheet causing swelling when heated. The lap strip weld is a better method of lap-welding and is often used for joining inner liners of pipe sections. The two meeting surfaces are cemented and sealed by welding a 1" wide step-shaped strip. Welding is done with a flat tip or Autoseal tip with shaped roller.

Preparation for Welding Preparing Surfaces to Be Lined

Metal: Metal surfaces must be sandblasted or grit blasted to remove rust, scale, coating, grease, moisture, etc. Weld spatter must be removed and rough welds ground smooth. After blasting, all surfaces are primed.

Concrete: Concrete surfaces must be clean, dry, and free of loose particles and foreign matter. All surfaces to be lined should be etched with a hydrochloric acid solution and washed down with water. The surface is then dried thoroughly before application of adhesives. The finished surface should be rough to support good adhesion.

Wood: Wood surfaces must be seasoned, clean and free from knots and resin. Plywood surfaces are satisfactory because of strength, minimum shrinkage, and freedom from resins.

Preparation of Lining Materials

Plasticized PVC Sheet: Sheet should be cleaned with an approved safety solvent to remove all dust, grease, etc. Sheets should be preheated to 100° F and preheated before welding. The starting end of corner strips should be scarfed at a 30° angle on the bottom. The combination flexible and rigid sheets are prepared in the same manner as above. Welding strips are rigid PVC and are either tacked or cemented in place and then back-welded. Refer to manufacturers for application instructions.

F.E.P. Fluorocarbon: Bonding to metal is achieved with special adhesives or by heat pressing without the use of adhesives. The material is heated to approximately 550° and pressed on the metal at 500 to 2000psi. Prepara-

tion for welding and strip must include positive ventilation away from the work area, since toxic fumes are emitted when the material is brought to the melting point.

Welding Procedures Plasticized PVC

Hand Welding Flat and Corner Strip: Take the flat strip with the free hand and with a slight amount of pressure directed toward the base material, **hold the strip perpendicular to the joint.**

Begin a fanning motion with the flat tip so that the strip and base material are heated equally. As the materials begin to flow at the fusion point and on the sides of the strip and moving along the joint on the base material. The welding tip should be held 1/4" to 1/2" from the work.

Hand welding of plasticized corner strip is similar to the method described with the flat strip except that a "V" tip is used in place of the flat tip. The "V" tip produces a heat pattern which conforms to the shape of the corner strip and base material. The fanning motion of the welder is once again utilized while the strip is pressed into the corner at a 45° angle. Visual inspection of the weld as it progresses should reveal flowing material along the sides of the strip and at the fusion point.

Hand welding of both flat and corner plasticized strip is facilitated by the use of a strip feeder, which passes the strip through a hollow handle of the strip feeder and under a roller. The use of this tool allows more uniform pressure to be applied on the welding strip, resulting in a more consistent weld. In addition, the strip feeder removes the operator's hand from the heat source.



**Welding Flat Strip by Hand
Using Strip Feeder**

Hand Welding Flat Strip



Semi-automatic Welding of Plasticized Vinyl Joint Strips - "Autoseal" Tip

Start of Weld: Hold the torch vertical or at a 90° angle to the work. Place end of tip approximately 1/2" beyond starting point on base material and feed triangular or flat strip into depression behind and under roller of tip. The strip should immediately be pushed down until it rests against the base material.

With torch still at a 90° angle to work, lift torch slightly until shoe rests on top side of strip, then press strip down with end of tip and start a quick tamping motion while feeding strip by hand. Continue tamping motion and at the same time, "walk" shoe or tip along strip for about 2". Tamping prevents overheating of strip and base material and consequent stretching or tearing of the strip by pulling the torch along when the strip is too soft.

As strip begins to feel solid under the shoe, discontinue tamping motion and lower the angle of the torch to base material. The torch may now be drawn over the joint at a controlled rate. Proper rates of welding should be between 18"-24" per minute. A proper seal will show material flow on both sides of the strip.

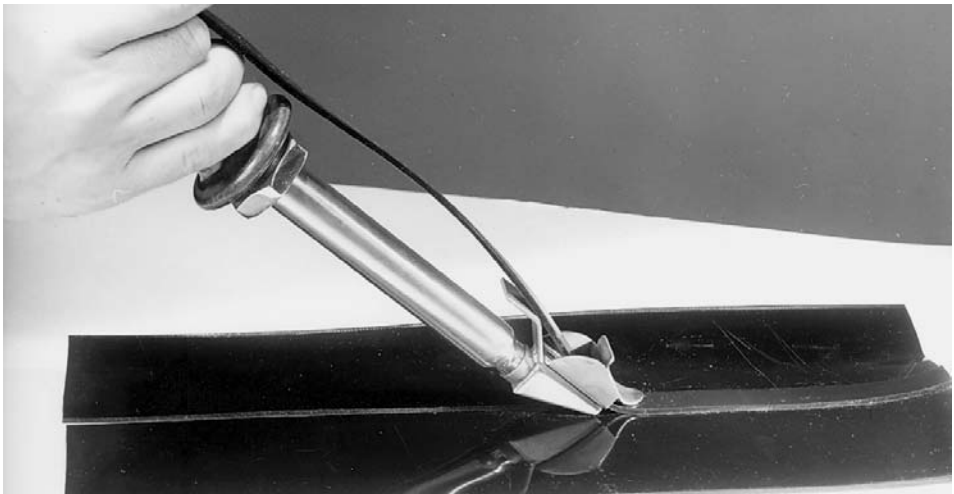

Welding Flat Strip – Auto seal

Once the welding operation has been started, it may be continued with one hand and the forward motion of the torch will automatically feed the strip through the tip. When the operator sees that the proper seal is being made, a constant pressure and rate of welding should be maintained. If operation must be slowed up, torch should once again be brought to 90° angle with base material and tamping motion resumed. With experience, starts can be made directly in the corner of a tank. By splicing the strip already applied and the piece about to be applied, a satisfactory joint can be made at any time.

Care should be taken not to blister or burn the sheet or strip material since this will yield an unsound weld. Welds cannot be properly repaired by reheating the weld and exerting pressure on the strip. A faulty weld should be cut away, cleaned and rewelded.

Welding Flexible - Rigid Laminated PVC Sheet

Butt joints are used whenever possible. Where space allows a 3/4" wide rigid butt strip is welded over the joint using a flat welding tip. The welded strip is then back-welded with rigid round rod. If space does not permit this method, the joint is skived to show an angle of 60° and welded with three passes of rigid round rod.

Corner joints are sealed using a rigid extruded angle. The angle piece is first tacked in place using a tacking tip or 3/32" rod intermittently along the edges of the angle. These edges are then back welded with rigid round rod. Angle strip is bent in the corners of the tank by cutting a 90° angle section in one leg of the strip, heating and bending the angle, and welding the seam.

Fluorocarbons

Although fluorocarbons are not yet very widely used as lining materials, their high heat distortion point and their chemical inertness make them ideal tank lining materials. F.E.P and P.F.A sheets can be butt welded using the techniques originally developed to weld Penton (Chlorinated Polyether) tank lining materials even though Penton is now seldom used as a liner.

Hand Welding Flat and Corner Strip: The procedure for welding Teflon flat and corner strip by the conventional hand method is similar to that described for flexible PVC. The flow of hot gas should be about one half that used for PVC to prevent splashing of the molten Teflon. Welding temperatures should be between 600° F and 650° F. A satisfactory weld can be achieved only when the underside of the strip and the top surface of the sheet are molten. As the weld progresses, a bead of molten material should be visible at the intersection of the strip and the sheet. The use of a roller to provide pressure on the strip is recommended for producing uniform welds.

Speed Welding Flat and Corner Strip: For sealing Teflon strip to sheet lining, tack strip in place with a tacking tip and, using round rod, speed weld both edges of the strip. Procedures are similar to those outlined for welding combination flexible-rigid linings.

Semi-Automatic Strip Welding: The rigid Autoseal tip makes semi-automatic welding possible with both Teflon flat and corner strip. A roller is used in place of a shoe to eliminate excess drag on the strip. Hot gas is introduced into the feeding chamber to soften the strip and make it pliable. A flat roller is used for flat strip and a slightly contoured roller used for the corner strip. These rollers are interchangeable on the same basic tip. The feeding chamber and brackets for the rollers may be detached from the lower part of the assembly and the latter part can be used as a conventional flat tip. Welding with the rigid Autoseal tip is greatly facilitated if the Teflon strip is

preheated to about 350° F. This is particularly true with the corner strip which has a larger cross-section than the flat strip and is stiff when cold. To start a weld in a corner or against the side of a tank, insert strip into feed-roller assembly and start weld same as using a flat tip. For first half inch, pressure in strip will have to be supplied by hand until roller can be brought to bear on top of strip. The torch should now be held at a 45° angle with the base material and the full width of the roller kept in contact with the strip. Welding should proceed at a rate which produces flow on both sides of strip. To finish a weld in a corner or against the side of a tank, the Autoseal tip must be replaced with a flat tip, and the weld finished by hand. When welding bottom corners in a tank, starts should be made in the corners and spliced halfway between corners. Strips should be cut on an angle at each start and spliced to allow neat overlapping. Splices should be overlapped 1/2" to 3/4".

Testing of Welds

The most efficient method of testing welds is by means of a high-frequency spark tester operating at more than 8000 volts. In cases where wood and concrete are to be lined, a grounded-wire system can be rigged so that wires are inserted between the butted sheets. The welds can be made directly over the wires with no detrimental effect on the joint. The liner is then spark tested.

Visual inspection of the welds should always reveal flow lines along both sides of the welded strip. Where these lines are not apparent, attempts should be made to pry the strip loose from the sheet with a knife. Practice welds can be tested by attempting to peel the strip from the sheet. The weld can also be cut for visual inspection.

Repair

Repairs can be made on punctured, torn, or faulty linings by cutting away the faulty section and cementing or welding a new section. Burned or cold welds must be cut and rewelded.



**Welded Flexible PVC Liner
in Large Plating Tank**

(Courtesy of Amercoat Corp.)

Chapter 8

Special Instructions

Instructions for Welding Individual Materials

The Welding techniques outlined in the preceding chapters apply to all of the weldable thermoplastics. Each type of thermoplastic, however, has individual physical and chemical properties which influence both the welding process and the finished product. Such factors as chemical resistance, recommended working temperatures, impact resistance, coefficient of expansion, structural rigidity, and notch sensitivity should be considered before selecting material. Information and recommendations on special applications can be made from material manufacturers. Information on special welding techniques and equipment will be furnished by Laramy Products Company upon request. General information for welding the more commonly used thermoplastics is given below. See table on page 49.

Polyvinyl Chloride

Three factors influence the welding of PVC: the type of PVC used (normal or high impact), the amount of plasticizer present in the material, and the quality of the welding rod.

There are two types of rigid (unplasticized) PVC available: Type I, normal impact, and Type II, high impact. Type II PVC is modified with rubber to increase impact resistance. However, welding temperatures and rates must be lower than those used for Type I, to avoid scorching.

Plasticizers are liquids or compounds added during extrusion to make the thermoplastic more flexible. Plasticizers are not used in rigid PVC pipe, fittings or sheet, but are used in some welding rods to improve the welding quality. Under normal conditions, a 10% plasticized rod gives better performance and strength, while the unpiasticized rod does not. The proper extrusion of the welding rod is important since voids and air pockets affect the ultimate strength of a weld. In addition, stresses in welding rod can be detected by a slight movement of the rod when placed in an oven. Always inspect the rod for lumpiness, voids and stress before welding. This applies to all materials.

Polyethylene

Several factors must be considered in the welding of polyethylene. Although there is a wide variance in composition, there are two types available for industrial purposes: regular or branched polyethylene, and linear or high

density polyethylene. The linear type is a more rigid and higher temperature material. Both types have a tendency to degrade in sunlight and oxidize in air. This degradation, due to ultraviolet rays, is easily solved by adding carbon black in the process of extrusion of polyethylene for use in outdoor applications.

Oxidation must be considered when welding polyethylene. Nitrogen must be used as the welding gas to eliminate oxidation at higher temperatures and achieve maximum strengths. Immediately upon extrusion, very slight oxidation occurs on the surface of the material. This very thin film is sufficient to affect the final welded product. For this reason, best results can be obtained by welding immediately after cutting the material and by removing the oxidized film from the rod with fine sandpaper or by scraping with a knife.

The welding rod and base material should be of the same composition, since this affects the bond of the weld. Polyethylene welding differs from that of PVC due either to more flexibility of the rod or the sharper melting point of polyethylene. Use large sized rods wherever possible and inspect for air inclusions, poor tolerance and stress.

The term "stress cracking", often included in discussions about polyethylene, refers to crazing, cracking or splitting of the material under certain conditions of chemical environment, heat or stress. Stress cracking results from welding materials of slightly different composition, welding at improper temperatures, and from subjecting materials to undue stress or chemical attack. Stress cracking can also be caused by oxidation. Proper rates of welding should be practiced to avoid stress: 5" per minute for hand welding and approximately 30" per minute for speed welding. Maximum weld strength is achieved 10 hours after weld is completed.

Polypropylene

A higher temperature material quite similar to linear polyethylene for welding procedures, polypropylene is susceptible to stress cracking and oxidation and requires the use of nitrogen to obtain maximum strength. Some splash of molten plastic will occur when welding this material but this does not affect the weld and can be eliminated by throttling down airflow.

F.E.P. Fluorocarbon

One of the newer thermoplastics, F.E.P. is a derivative of "Teflon"* and has the highest heat distortion point yet developed. The general techniques for welding are the same as for regular polyethylene. It is susceptible to stress cracking but will not oxidize in the presence of air so that an inert welding gas is not necessary. Gases evolved at temperatures above 400° are highly toxic and must be eliminated by adequate ventilation.

* Trademark of E.I. duPont deNemours & Co., Inc.

Acrylic – “Plexiglas” **

One of the first thermoplastics to be welded when the Germans, during World War II, used the process to mend bullet holes in airplane canopies. Acrylic requires a high temperature for welding, a slightly plasticized rod, and may be welded with compressed air. Welding procedures are the same as for PVC. Acrylic is susceptible to stress cracking and tends to froth and blow during welding. The flow lines on a finished weld will usually show air inclusion.

Most acrylics can be welded to themselves or to PVC using PVC rod. This makes them ideal for see-through applications such as dry boxes when clear PVC is not available.

PVC welding techniques are used in all cases. With both acrylics and PVC, extreme care should be taken to avoid charring of the material. Welding is accomplished with air at 400-450° F for PVC rod: 500-550° F for acrylic rod. The rod is normally held at a 90° angle to the weld seam with 2-3 pounds of pressure exerted on it.

** Trademark of Rohm & Haas Co.

High-Temperature PVC: Chlorinated PVC is best welded by hand at the present time to obtain maximum strengths of 80-100%. Since a high temperature is required to melt CPVC (300° F), a rod feeding device is recommended to maintain a constant 3 pound rod pressure without undue discomfort to the fingers from the heat.

On typical sheet and pipe seams, the edges should be cleaned and beveled prior to tack welding. The finish weld is accomplished with 600-650° F air temperature at the tip with 3-4 psi gas pressure. The 90° welding angle should be maintained. When welding, the rod will soften and a slight bulge will occur just above the weld. The rod should not be allowed to melt further and care should be taken to prevent scorching of the rod or the work through excessive heat.

ABS: Acrylonitrile/Butadiene/Styrene has excellent forming properties for most applications. ABS is available in normal and high-temperature types, either of which can be hand or speed welded as desired. Conventional ABS should be welded with air or inert gas at approximately 350-400° F: high temperature ABS at 500-550° F.

General Remarks

Stretching And Distortion

Regardless of the skill and technique of a welder, some stretching of the welding rod will always occur. Unless such stretching exceeds 15%, strength

and stability of the completed weld will be unaffected. As pointed out previously, excessive stretching occurs when the welding rod is leaned away from the direction of welding. In speed welding, stretching is caused too much pressure on the rod, or plastic residue on the shoe and in the pre-heating tube. When a thermoplastic rod is heated sufficiently to form a weld it becomes soft, and tends to stretch. Upon cooling, it contracts considerably. When this happens, stresses caused by stretching produce cracks and checks across the face of the weld. A simple method of determining the amount of stretch in a completed weld is to measure the length of the rod before and after welding.

It has been stated that thermoplastics when heated tend to revert to their original shape. In multi-layer welds, deposited beads are, of course reheated in the process of laying new beads one on another. For this reason, stretching in multi-layer welds must be held to a minimum since checks and cracks caused by stretching will show up as void in the finished weld and can not be detected by visual inspection. When making multi-layer welds, allow ample time for each weld pass to cool before proceeding with additional welds. To save time and give added strength to multi-layer welds alternate from one side of the groove to the other. In addition to stretching of the rod, welding also tends to cause distortion to the base material. This is particularly true when multi-layer single "V" butt welds are being made.

As in metal welding, sudden heating and eventual cooling causes considerable expansion and contraction in the welded materials. Unlike metals, however, thermoplastics are notably poor conductors of heat, and stresses created by alternate heating and cooling are confined to a much smaller area. This concentration of heat combined with an expansion coefficient eight times that of steel creates great stresses in the welded plastic material. Shrinkage of a weld upon cooling is greater near the crown than at the root. For this reason when welding sheets, material should be offset before welding to compensate for distortion created by single "V" and fillet welds. Also, it is advisable to preheat the general area to be welded in order that the sheet can better absorb the stresses caused by welding. Because of the absence of misdirected and wasted heat on speed welding, less distortion is imparted to the base material than with hand welding. Use of triangular welding rod in place of multi-layer welds with round welding rod also decreases the amount of distortion, since one weld replaces several welds.

Dressing And Repairing Welds

Contrary to metal welding procedures, it is not good practice to dress plastic welds, unless a flat surface is required. Weld strength is reduced as much as 25% when the crown is removed, and frequently careless sanding or grinding will make notches in the weld, creating definite weaknesses. This is particularly true of the more notch-sensitive materials, such as PVC. If dressing is advisable on a completed weld, it may be done with file or rotary sander.

Welds which appear to be burned or charred or which lack cohesion with the base material should be removed and a new weld made. Welding over faulty welds does not remove the original weakness; a faulty weld should, therefore, be completely removed with a knife, rasp, router or sandpaper and the joint welded anew. Poor starts and cold welds can be removed easily by reheating and cutting with a knife.

Welding Threaded And Socket - Cemented Pipe Fittings

Plastic pipes and fittings are joined together by three basic methods: threading, welding, and cementing with a solvent cement. To assure maximum strength and leak tightness, combinations of these three methods are often used. Information regarding threading and cementing of pipes and fitting can be obtained from materials suppliers. Only the welding and back-welding of fittings will be covered here.

Threaded fittings should be welded only to repair leaks, since the sole advantage of threading is to provide a pipe system which may be dismantled and its components reused. Since only heavy walled (schedule 80) pipe should be threaded, this method is recommended only for **temporary installations**. Before a threaded joint can be properly back-welded, the exposed threads in the weld area adjacent to the fitting should be removed with a file to provide smooth surfaces for welding. A full fillet weld is recommended when back-welding threaded fittings. A slight drip leak can be repaired with a single weld using 1/8" rod. More serious leaks require three welds and five welds in the case of pipes more than 2" in diameter.

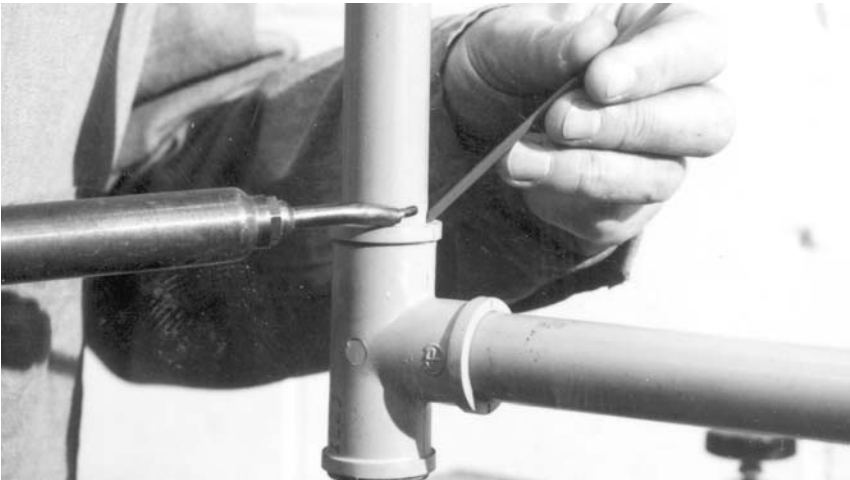

Back-Welding PVC Socket Fitting

Cemented fittings are back-welded to repair a leaking joint and to insure against leaks. When repairing leaks, do not back-weld the fitting while it is leaking since the moisture will prevent a good bond, rough up the weld

surfaces with a file or sandpaper before welding. A single bead weld will repair slight leaks. Serious leaks require a full fillet weld.

Socket type fittings allow rapid installation of a piping system and assure strong joints with thin wall (schedule A and 40) pipe, as well as heavy walled (schedule 80 and 120) pipe. Once installed, the system cannot be dismantled and reused unless the pipe is cut adjacent to the fitting and new fittings procured. Socket fittings can be cemented, cemented and back-welded, or completely welded.

Welding socket fittings to pipe without solvent cement takes longer, but the system may be placed in service immediately. Strengths are approximately the same as those achieved with cement. If polyethylene is used, the fitting must be welded. Before welding, fully insert fitting on pipe and tack or clamp into place. Surfaces to be welded should be cleaned with approved solvents. The number of passes to be used should be in accordance with those illustrated on page 52.

Shaped Rod

Highly-successful welding is being accomplished with triangular and oval cross-section rod. These rods permit a complete weld in fewer passes and have a smoother, more finished appearance than conventional rod welds. Rod shapes can be tailored to almost any configuration for large or small seams. Special speed tips can be designed to accommodate the various cross-sections of shaped rod.

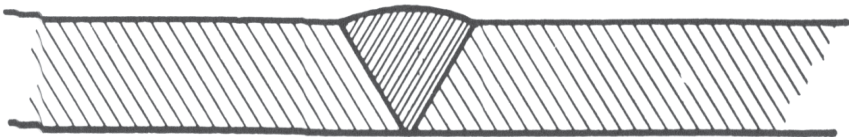

Triangular Rod: Triangular rod is designed to fit a beveled seam and deliver a flat, finished weld in a single pass. It is smooth, strong and neat in appearance. Although welding speed is slower in inches per minute, the seam is finished in a fraction of the time required by multiple passes with small diameter round rod.



Oval Rod: This cross-section reduces the number of passes required to fill a weld seam and produces a smooth-crowned weld of much neater appearance. Several round rod beads may be deposited in the root of the weld before applying the oval rod.

Chapter 9

Inspecting, Testing And Evaluating Welds

The strength of a completed weld depends on a combination of factors. In order of their importance, these are as follows:

1. Strength of base material.
2. Temperature of welding gas.
3. Pressure on welding rod during welding.
4. Type of weld.
5. Preparation of materials before welding.
6. Skill of welder.

The strength of butt welds is in accordance with the type of weld used. Dressing decreases strength of completed welds by approximately 25%. Welds equivalent to less than 75% of original material strength should be considered unsatisfactory.

Visual Inspection

Regardless of the material welded, a good weld will always show flow lines or waves on both sides of the deposited bead. These waves indicate the welding surface of the rod was heated sufficiently to allow the materials to flow and enough pressure was exerted on the rod to force the viscous material out of the weld bed, permitting bonding of the softened plastic parts.

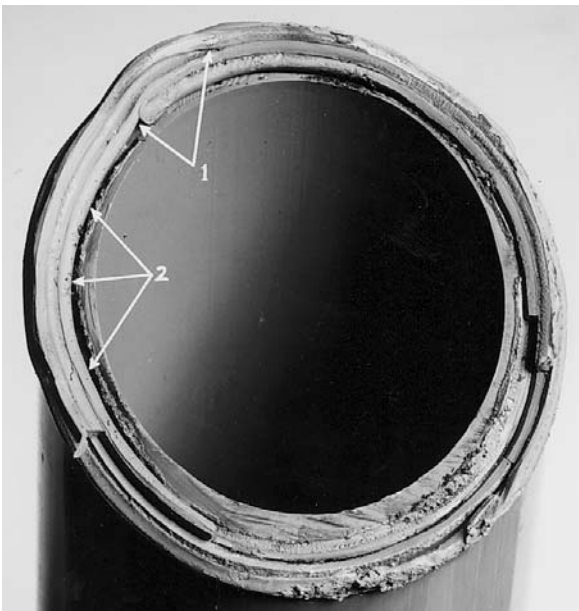

1. Voids
2. Scorching

Poor Penetration Throughout

Visual Inspection of Broken Weld

Causes of Common Welding Troubles

POROUS WELD

WHY:

1. Porous weld rod
2. Balance of heat on rod
3. Welding too fast
4. Rod too large
5. Improper starts or stops
6. Improper crossing of beads
7. Stretching rod

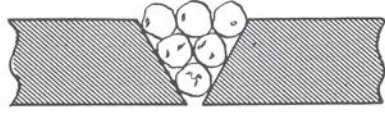

CORRECTION:

1. Inspect rod
2. Use proper fanning motion
3. Check welding temperatures

4. Weld beads in proper sequence
5. Cut rod at angle, but cool before releasing
6. Stagger starts and overlap splices 1/2"

POOR PENETRATION

WHY:

1. Faulty preparation
2. Rod too large
3. Welding too fast
4. Not enough root gap

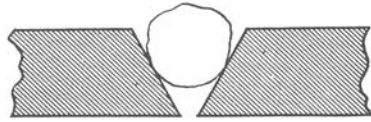

CORRECTION:

1. Use 60° bevel
2. Use small rod at root
3. Check for flow lines while welding
4. Use tacking tip or leave 1/32" root gap and clamp pieces

SCORCHING

WHY:

1. Temperature too high
2. Welding too slow
3. Uneven heating
4. Material too cold

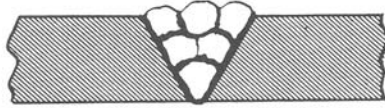

CORRECTION:

1. Increase air flow
2. Hold constant speed
3. Use correct fanning motion
4. Preheat material in cold weather

DISTORTION

WHY:

1. Over-heating at joint
2. Welding too slow
3. Rod too small
4. Improper sequence



CORRECTION:

1. Allow each bead to cool
2. Weld at constant speed – use speed tip
3. Use larger sized or triangular shaped rod
4. Offset pieces before welding
5. Use double V or back-up weld
6. Back-up weld with metal

**CORRECT
ANGLE**

**TO MAKE BETTER
CORRECT
SPEED**

and How to Correct Them.....

WARPING

WHY:

1. Shrinkage of material
2. Overheating
3. Faulty preparation
4. Faulty clamping of parts

CORRECTION:

1. Preheat material to relieve stress
2. Weld rapidly – use back-up weld
3. Too much root gap
4. Clamp parts properly – back-up to cool
5. For multilayer welds – allow time for each bead to cool

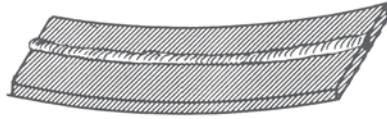

POOR APPEARANCE

WHY:

1. Uneven pressure
2. Excessive stretching
3. Uneven heating

CORRECTION:

1. Practice starting, stopping and finger manipulation on rod.
2. Hold rod at proper angle
3. Use slow uniform fanning motion, heat both rod and material

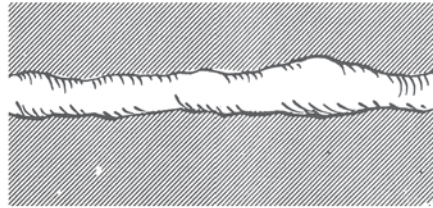

(For Speedwelding: use only moderate pressure, constant speed, keep shoe free of residue.)

STRESS CRACKING

WHY:

1. Improper welding temperature
2. Undue stress on weld
3. Chemical attack
4. Rod and base material not same composition
5. Oxidation or degradation of weld

CORRECTION:

1. Use recommended welding temperature
2. Allow for expansion and contraction
3. Stay within known chemical resistance and working temperatures of material
4. Use similar materials and inert gas for welding
5. Refer to recommended application

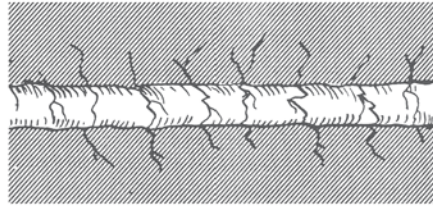

POOR FUSION

WHY:

1. Faulty preparation
2. Improper welding technique
3. Wrong speed
4. Improper choice of rod
5. Wrong temperature

CORRECTION:

1. Clean materials before welding
2. Keep pressure and fanning motion constant
3. Take more time by welding at lower temperatures
4. Use small rod at root and large rods at top – practice proper sequence.
5. Preheat materials when necessary
6. Clamp parts securely

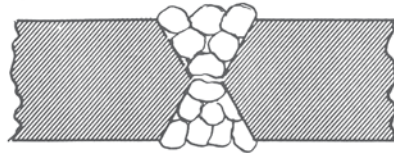

PLASTIC WELDS: USE
CORRECT
TEMPERATURE

CORRECT
PRESSURE

Visual examination of multi-layer welds can be accomplished by cutting across the axis of the weld and polishing cross-section. Close inspection will reveal any faults present, such as voids, scorching, notching, etc.

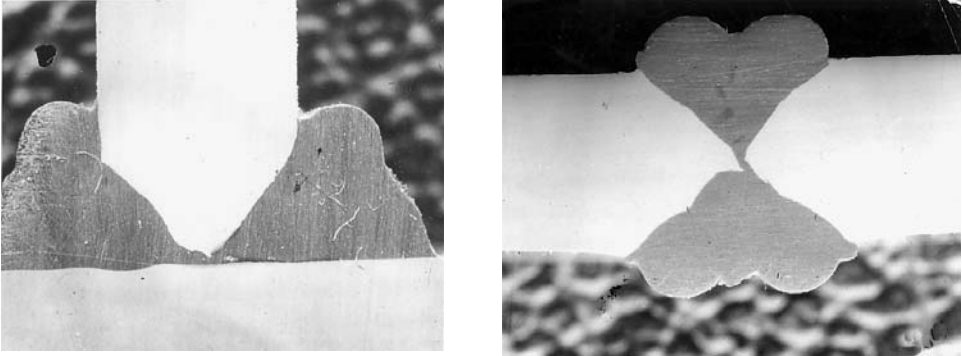

Cross Sections of Completed Welds

Testing Of Welds

Procedures for testing plastic materials have been established by the Society for Testing Materials, and the Society of the Plastic Industry, as well as by individual plastic fabricators. These may be divided into three general categories: destructive, nondestructive, and chemical.

Methods used for mechanical or destructive weld testing are: tensile testing, bending, removal of rod, burst testing, and impact testing. These methods are used immediately after welds are completed or after a twenty-four hour curing period.

Tensile Test

Used primarily to evaluate butt welds on rigid sheet. The method outlined by the Society of the Plastic Industry is as follows: using 3/16" sheet, prepare a specimen approximately 8"x6". Cut specimen in halves, each 4"x6", and bevel both pieces to a double "V" by sanding one 6" side of each piece to an angle of 30°, leaving a 1/64" flat surface on the apex of each bevel. Clean bevel surfaces thoroughly and clamp test specimen securely to a bench leaving 1/64" space between flattened apexes. Adjust welding torch to correct temperature and apply two or three beads on each side of specimen, using small diameter rod for root welding and larger rod to complete weld. Cut at least five specimens, approximately 1/2" wide, and pull each in tensile tester at a rate of 0.025" per minute. Calculate welding value in percentage as follows:

$$\frac{\text{Breaking strength of weld} \times 100}{\text{Original tensile strength of material}} = \text{welding value}$$

Bending Test

Prepare specimen as described for tensile test. While still hot, bend double along axis of weld. The bead should cohere to the beveled surface of the sheet. A similar test, conducted 24 hours after welding, on a pull test specimen should not break readily when bent 90° by hand. Examine breaks to determine if the base material has been broken. If the base material is broken the weld should be adequate.



Bending Test

Removal Of The Rod

A simple method for detecting ineffective bonding in a completed weld is to allow the rod to extend beyond the weld area. While the rod is still hot, grasp the free end of the rod and attempt to pull out the welded section. If properly welded, the filler rod will break before it pulls away from the base material. This method tests only the last 1 or 2 inches of the weld to be completed. To test the entire section, attempt to remove the deposited filler rod with a pair of pliers or a knife after the material has cooled. Break the weld loose with a hammer and screwdriver and examine. If properly bonded, fragments of the base material should cohere to the broken rod and vice versa. Use of colored rod facilitates inspection of weld.

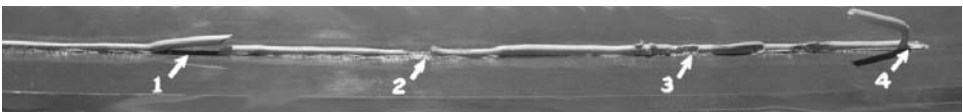

1. Cold Weld
2. Stretched Weld
3. Attempted Removal of Sound Weld (Pliers)
4. Hand Removal of Sound Weld White Hot

Testing of Weld – Removal of Rod

Burst Test

The most effective method for testing pipe butt welds and fillet welds on fabricated fittings and couplings is to cap the open ends of pipe and subject the weld to hydrostatic pressure from tap water. Tapered plugs may also be welded for test using edge welds or full fillet welds.

Impact Test

The final destructive test is that of subjecting the weld to sudden impact, such as hitting with a hammer, etc. When broken, examine for faulty bonding, voids, scorching, etc.

Nondestructive Tests

Cracks, porosity, and lack of bonding can be detected in welded containers by filling them with water and checking for leaks. Another common method is to apply air pressure to the inside of a capped container and immerse it in water. Bubbles of escaping air will indicate a leak. A pipe system can be checked by painting the joints with a soapy solution, then placing the capped system under air pressure. Bubbles will indicate slow leaks. To locate fine porosity in welds, a high frequency spark tester must be used. Operating at 10,000 to 30,000 volts, this instrument sends a shower of sparks over the surface of the plastic which has been grounded with a metal backing. Porosity is indicated by a straight line of sparks passing through the weld to the grounded metal. This method is used for testing plasticized and rigid tank linings. Air inclusions and voids in natural color polyethylene and polypropylene welds can be detected by using a bright light held at an oblique angle to the work. The most effective nondestructive method for testing welds is the use of an Xray or fluoroscope machine which is capable of revealing voids and scorching in hidden welds on finished products.

Chemical Tests

Immerse welded test specimen in acetone for a period of two to four hours. Faulty welds will separate from base material and residual strains and stresses in the welded section will be noted by swelling of the material. Delamination and disintegration indicate defective materials. After acetone immersion, pry out welded beads and inspect for fusion. Good weld beads should be difficult to pry loose.

Dye penetrant on a completed weld also serves as an inspection aid, since a good weld will not allow the penetrant to seep through.

Where temperature and chemical attack approach the known limits of a chosen materials resistance, welded specimens should be tested chemically. Butt weld and corner welds should be immersed in the intended chemi-

cal environment and placed under stress while proposed temperatures are maintained. If stress and cracking and separation of welds is apparent, the material is unsatisfactory.

Failure of thermoplastic welds, when subjected to tests listed above, is caused by lack of fusion between bead and base material, voids or porosity, lack of fusion between beads themselves, and finally, lack of fusion between the lands of the base materials. Any one or combination, may be responsible for weld failure.

**4 ESSENTIALS
for
Making Even Better Plastic Welds**

- | | |
|------------------------|------------------|
| 1. Correct TEMPERATURE | 3. Correct ANGLE |
| 2. Correct PRESSURE | 4. Correct SPEED |

Chapter 10
Useful Information

MATERIAL WELDING DATA

	Welding Temp. in F.*	Welding Gas	Weld Strength in %	Forming Temp. in F.	Cementable	Specific Gravity	Support Combustion	Laramy Element
High-Temperature PVC	500-550	Air	75-90	400	Yes	1.55	No	LP_27
ABS Butyrate	350-400	Air	65-85	300	Yes	1.01	Yes	LP_27
High-Temperature ABS	500-550	Air	65-85	400	Yes	1.06	Yes	LP_27
Acrylics with PVC Rod	500-550	Air	65-85	280	Yes	1.19	Yes-Sheet No-Rod	LP_27
Acrylics with Acrylic Rod	600-	Air	60-80	280	Yes	1.19	Yes	LP_27

*Measured 1/4" from welding tip.

THERMOPLASTIC WELDING DATA

	PVC TYPE I	PVC TYPE II	PVC PLASTICIZED	POLYETHYLENE REGULAR	POLYETHYLENE LINEAR	POLYPROPYLENE	CHLORINATED POLYETHER	FEP FLUOROCARBON	ACRYLIC
Welding Temp. °F*	500 to 550	475 to 525	500 to 800	500 to 550	550 to 600	550 to 600	600 to 650	550 to 650	600 to 650
Welding Gas	Air	Air	Air	Inert	Inert	Inert	Air	Air	Air
Butt-Weld Strength - %	75-90	75-90	75-90	80-95	50-80	65-90	65-90	80-95	75-85
Maximum Continuous Service Temp. °F	160	145	150	140	210	230	250	250	140
Bending & Forming Temperature	250	250	100	245	270	300	350	550	280
Cementable	yes	yes	yes	no	no	no	no	no	yes
Specific Gravity	1.35	1.35	1.35	.91	.95	.90	1.4	2.15	1.19
Support Combustion	no	no	no	yes	yes	yes	no	no	yes
Odor Under Flame	HCL	HCL	HCL	Wax	Wax	Wax	Sweet Chlorine	Pungent	Sweet
LARAMY ELEMENT	LP-27	LP-27	LP-27	LP-27	LP-27A	LP-27A*	LP-27A	LP-27A	LP-27A

*Measured 1/4" from welding tip.

*Polypropylene - Speed Welding LP-51

COMPARISON OF WELD STRENGTH OF BUTT JOINTS IN RIGID PVC

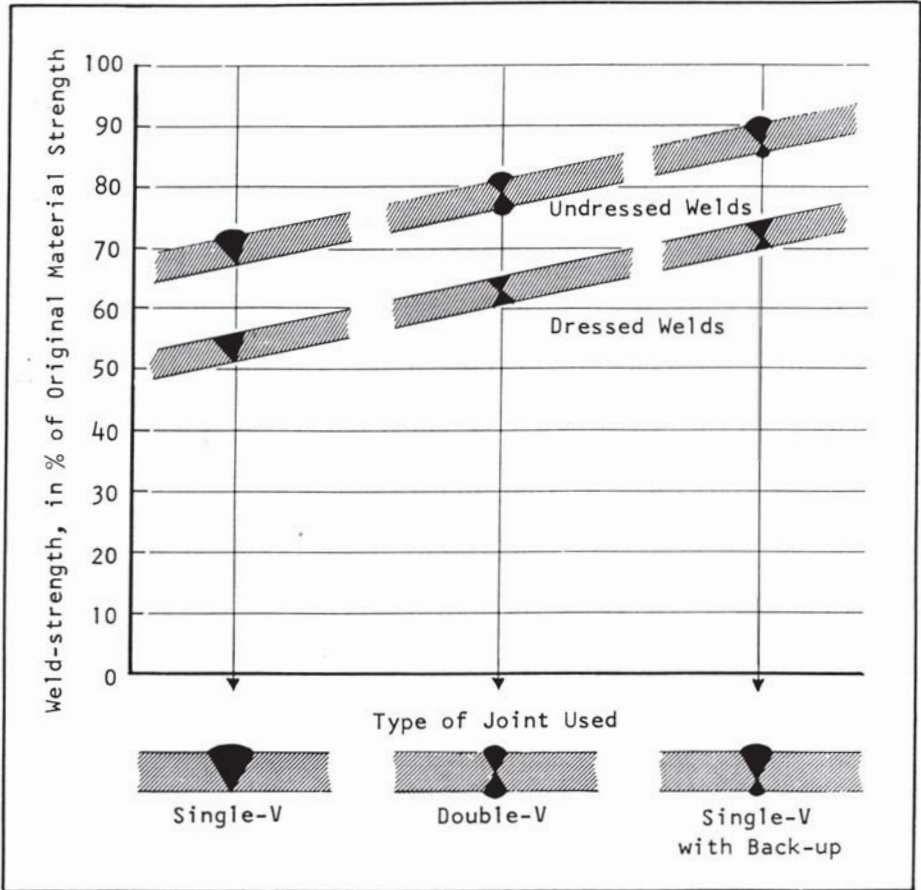

**RECOMMENDED ROD SIZES AND APPROXIMATE NUMBER OF BEADS
REQUIRED FOR BUTT WELDING THERMOPLASTIC SHEET**

Sheet Thickness (in.)	Root Gap (in.)	Rod Size (inches)		Number of Following Beads	
		Root Bead	Following Beads	Single V	Double V (each side)
1/16	1/64	3/32	none required	_____	not practised
3/32	1/64 - 1/32	1/8 Single V	none required	_____	_____
		3/32 Double V	none required	_____	_____
1/8	1/32	3/32 Single V	3/32 or 1/8	2 or 1	_____
		1/8 Double V	_____	_____	none required
5/32	1/32 - 1/16	3/32 Single V	1/8	2	_____
		1/8 Double V	_____	_____	none required
3/16	1/16	1/8 Single V	5/32	2	_____
		5/32 Double V	none required	_____	_____
1/4	1/16 - 3/32	1/8 Single V	1/8	5	_____
		1/8 Double V	1/8	_____	2
3/8	3/32	5/32 Single V	5/32 or 3/16	9 or 5	_____
		5/32 Double V	5/32	_____	2

WELDING PVC FITTINGS

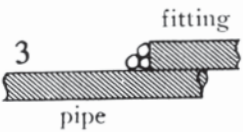
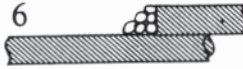
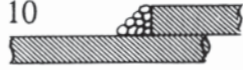
Size	Threaded	Socket Weld With Cement	Socket Weld Without Cement
1/2" thru 2"	1	1	3  fitting pipe
2-1/2" thru 4"	1	1	6 
Over 4"	1	1	10 

NOTE: Illustrates number of passes at face of fitting when full strength of fitting is desired.
Number of passes shown are with 1/8" diameter rod.

Chapter 1 1

Training Exercises

Since the quality of a weld is directly proportionate to the skill of the welder, the inexperienced welder should practice all types of welds before attempting work on production items. The following outline is suggested as a guide for the training and testing of welders.

1. Operation and Maintenance of Equipment

- a. Disassemble torch and inspect parts. Note procedure for changing heating elements.**
- b. Connect torch and practice changing tips.**
- c. Set correct temperatures for welding various plastics.**

2. Tacking

- a. Use tacking tip to tack scrap pipe and sheet together. Test for strength.**

3. Hand Welding Exercise

- a. Using welding torch with round welding tip, 1/8" rod and flat sample sheets of plastic, weld single stringer beads starting in the middle of the sheet and alternately work out from the center.**
- b. Practice cutting rod with nippers.**
- c. Practice starting welds.**
- d. Practice manipulation of rod with fingers.**
- e. Practice stopping.**
- f. Practice trimming and removal of welded bead with knife.**
- g. Practice re-starting bead after stopping.**
- h. Practice welding bead atop beads.**
- i. Practice overlapping and crossing beads.**
- j. Test for stretch by measuring rod before and after welding.**
- k. Test for bonding by stripping rod from sheet while still hot. Also, attempt to remove rod when cooled.**

Speed Welding Exercise

Weld single beads using same materials as above and speed tip. Concentrate on proper angle of welding torch, rate of speed, and

correct pressure on welding rod. Practice:

- a. Cutting rod.
- b. Starting.
- c. Stopping.
- d. Re-starting
- e. Welding beads atop other beads.
- f. Testing completed welds.

Test Samples To Prepare

The following sample products should be undertaken by the plastic welding trainee as a means of familiarizing himself with the procedures discussed and illustrated throughout the instruction manual. When the prospective welder has completed these projects successfully, he is well on the way to becoming familiar with everyday welding problems and procedures encountered in the field of plastic welding.

Sample No. 1 - Double "V" Hand Weld

- a. Prepare test specimen of double "V" hand weld, according to procedures described and illustrated on page 13. Turn over sheet and check root weld after first pass for flow.
- b. Cut sections from completed specimen weld; sandpaper cross-section of weld. Examine visually, then give bend test. The sample should break alongside of weld in material or through middle of weld.

Sample No. 2- Single "V" Speed Weld

- a. Prepare test specimen of single "V" speed weld, according to procedures described on page 13.
- b. Use tacking tip to assemble pieces for final welding.
- c. Speed weld root bead. Use 1/8" rod for first pass; then 5/32" rod for five passes.
- d. Cut sections from completed weld specimen; sandpaper cross-section of weld. Inspect visually. Give four hour acetone test described in Chapter 9.

Sample No- 3- Hand and Speed Lap Weld

- a. Prepare two sheet samples 1/8" x 2" x 20", with no bevel.
- b. Overlap 20" sides 1". Assemble by running tacking tip full length on both sides.
- c. On one side hand weld four beads; use 1/8" rod. Mark off four lines with china pencil 3" apart; number them 1, 2, 3, 4. Use these numbers

- to mark starts and stops respectively for welded beads 1, 2, 3, 4.
- d. Turn to other side and mark, as above, four starting and stopping points. Make stops in the same beads and same locations as on the first side. Weld four beads.
 - e. Using bandsaw, cut sheet at each stopping point; also cut between each starting and stopping point. Sandpaper each weld cross-section and inspect visually.
 - f. Take one end piece, one piece cut at stopping point, and one piece cut between a starting and a stopping point; immerse in acetone for 4 hours. After removal from acetone, welds should not separate, delaminate, or disintegrate.

Sample No. 4- Pipe Butt Weld and Back Weld

- a. Using 2" schedule 40 pipe with single bevel, prepare two 12" sections.
- b. Tack weld pipe sections together using either tacking tip or 3/32" tacking rod.
- c. With one length of 1/8" welding rod, weld three continuous passes around pipe.
- d. On one end of butt welded pipe, back-weld socket cement fitting using 1/8" rod and three separate welding passes.
- e. On opposite end of pipe prepare mitered 90° elbow. Bevel edges, tack and root weld with 1/8" rod. Finish weld with five separate welding passes using 1/8" rod. Stagger starts.
- f. Cut off welded fitting with bandsaw. Saw weld into quarters; examine visually and immerse in acetone.
- g. Cut mitered elbow from butt welded pipe section. Break weld, using hammer or vise. Examine visually.
- h. Fillet weld plugs into both ends of butt welded section; hydrotest to tap water psi. Give dye penetrant test. Cut into quarters and inspect visually. Test one piece with acetone immersion test.

Sample No. 5- Flat Circular Welding

- a. Cut two 6" square samples of sheet stock.
- b. Using 1/8" rod, hand and speed weld spiral connecting circles without changing position, starting in the center of the sheet and working out. This is an exercise for welding at all angles. Mark weld sections which appear to be unsatisfactory.
- c. Cut sections from completed samples and inspect. Immerse in acetone.

For further information on equipment and tools described in this book, please contact
Laramy Products, LLC, Box 1168, Lyndonville, VT 05851.

NOTES

NOTES

NOTES
